



110 Sunray Drive, Suite 1
Johnstown, PA 15905
Phone: (814) 255-5243
Fax: (814) 255-1805

A PA Municipal Corporation

www.upperyodertownship.org

RULES AND REGULATIONS GOVERNING SANITARY SEWER SERVICE

Schedule of Rules and Regulations governing the use of
Sanitary Sewer Service in the Upper Yoder Township
Authority Service Area

Effective: OCTOBER 16, 2023

NOTICE

THE AUTHORITY RESERVES THE RIGHT TO CHANGE OR AMEND THESE
RULES AND REGULATIONS AND ANY OR ALL RATES, CHARGES OR FEES
AT ANY TIME BY RESOLUTION AND WITHOUT PRIOR NOTICE BY WAY OF
ADVERTISEMENT IN A NEWSPAPER OF GENERAL CIRCULATION.

DULY ADOPTED BY THE UPPER YODER TOWNSHIP AUTHORITY THIS 16th DAY OF OCTOBER, 2023, THE FOLLOWING DOCUMENTS AND RATE AND FEES, **SCHEDULES "A" THROUGH "M,"** ATTACHED HERETO, ARE CONSIDERED TO BE A PART OF THESE RULES AND REGULATIONS.

UPPER YODER TOWNSHIP AUTHORITY

Vernon Walker

John Heider

James Peters

James [unclear]

Kevin H. Evans

ATTEST:

Alice E. Hummel

TABLE OF CONTENTS
UPPER YODER TOWNSHIP AUTHORITY SEWER RULES

	<u>Page</u>
DEFINITIONS	2
APPLICATION FOR SERVICE	4
GUARANTY DEPOSITS	5
CAPACITY FEES	5
SERVICE CONNECTION	6
STOPPAGE OF SERVICE	6
LINE EXTENSION RULE	6
BUILDING SEWER	7
INSPECTION AND TESTING OF NEW CONNECTIONS	8
INSPECTION AND TESTING OF EXISTING CONNECTIONS/WITHOUT SALE, FINANCING OR TRANSFER PENDING	9
SEWER COMPLIANCE AT SALE, TRANSFER, ASSIGNMENT AND MORTGAGE/FINANCING REGULATIONS	10
DETRIMENTAL WASTES	14
DEDUCTION METERS	15
BILLS AND PAYMENT	15
ENFORCEMENT	16
DISCONTINUATION OF SERVICE	17
GENERAL SUMMARY OF PROVISIONS	17
EXISTING SERVICE, APPLICATION FOR SERVICE/RESIDENTIAL	Schedule "A"
EXISTING SERVICE, APPLICATION FOR SERVICE/COMMERCIAL-INDUSTRIAL	Schedule "B"
APPLICATION AND AGREEMENT FOR NEW SEWER SERVICE	Schedule "C"
APPLICATION FOR AND CERTIFICATE OF COMPLIANCE	Schedule "D"
SPECIFICATIONS FOR BUILDING SEWER INSTALLATION AND BUILDING SEWER INSTALLATION DIAGRAM	Schedule "E"
TIME EXTENSION AGREEMENT FOR SANITARY SEWER COMPLIANCE (RESIDENTIAL)	Schedule "F"

TABLE OF CONTENTS
UPPER YODER TOWNSHIP AUTHORITY SEWER RULES

	<u>Page</u>
TIME EXTENSION AGREEMENT FOR SANITARY SEWER COMPLIANCE (COMMERCIAL)	Schedule "G"
GENERAL GUIDE FOR CERTIFICATION OF PRESSURE TESTING BUILDING SEWERS	Schedule "H"
RESERVED	Schedule "I"
"A" AGREEMENT FOR CONTRACTORS	Schedule "J"
APPLICATION FOR DEVELOPERS PACKET	Schedule "K"
"AS-BUILT" PLAN SUBMISSION REQUIREMENTS	Schedule "L"
RATES AND FEES	Schedule "M"

UPPER YODER TOWNSHIP AUTHORITY

RULES AND REGULATIONS GOVERNING SANITARY SEWER SERVICE

A copy of the Rate Schedules and the Rules and Regulations governing the Sanitary Sewer System are open to inspection at the Authority's office.

ARTICLE 2 DEFINITIONS

AIR OR WATER PRESSURE TEST

Testing by water wherein all buried and under-slab piping (both inside and outside the foundation) is filled with water and a temporary water column is introduced to a minimum of ten (10) feet of head to the highest portion of the buried and under-slab piping, with no water loss observed during a fifteen (15) minute period.

Testing by air wherein all buried and under-slab piping is pressurized with air to a minimum of five pounds per square inch (5 psi) and thereafter held for a period of fifteen (15) minutes with no noticeable pressure drop.

APPLICANT

A person applying for a Certificate of Compliance, Sanitary Sewer Pressure Testing Certificate or a Temporary Certificate of Compliance.

AUTHORITY

As used herein, the term Authority shall mean Upper Yoder Township Authority.

BUILDING DRAIN

The lowest horizontal piping of a drainage system which receives the discharge from soil, waste and other drainage pipes inside the walls of a building and conveys it to the Building Sewer at a point outside the inner face of the building wall.

BUILDING SEWER

All piping connected to the Authority's Sewer Lateral and extending to the Building Drain of the structure(s) and/or appurtenance(s) to which Sanitary Sewer Service is provided.

CASH SECURITY

Cash, certified check or treasurer's check.

CCTV INSPECTION

Closed Circuit Television Inspection (CCTV) inspections enable operators to monitor lines and pinpoint problems such as cracks, breaks, sags and obstructions which impede water tightness.

CERTIFICATE OF COMPLIANCE, SANITARY SEWER PRESSURE TESTING

An official statement from the Authority stating that there are no unlawful connections to the sanitary sewer lines on the real property to be sold, transferred or mortgaged, or if otherwise required to be tested.

CUSTOMER

The individual or individuals, partnership, association, company, municipality, or any entity whatsoever and who is defined by the Pa. Municipal Claim and Tax Lien Law Act of May 16, 1923, as amended, as Owner of property, as hereinafter classified, that has the use or benefit of the Sanitary Sewer System. Customer shall be the contractual applicant and shall be ultimately responsible for payment therefore, and shall comply with the Rules and Regulations of the Authority.

EQUIVALENT DWELLING UNIT (EDU)

The average amount of sewage flow expected to be generated by a single-family dwelling.

FLOW METERING

An instrument for monitoring, measuring or recording the rate of flow or discharge of a fluid through a sanitary sewer pipe to be used for diagnostic purposes.

GREATER JOHNSTOWN WATER AUTHORITY

The water service provider for Upper Yoder Township Authority customers or its successor.

IMPROVED AND CONNECTED REAL PROPERTY

Real property on which any building, driveway or parking pad, other surface or subsurface structure or improvement has been constructed, installed or erected, where the real property or any improvement on the real property is connected to the Township Sanitary Sewer Collection System.

INFLOW AND INFILTRATION (I & I)

Any surface water or ground water which enters the Sanitary Sewer System by any means. These Rules and Regulations prohibit any person from causing, allowing or permitting any quantity of Inflow and Infiltration to enter the Sanitary Sewer System.

JOHNSTOWN REDEVELOPMENT AUTHORITY

a/k/a Johnstown Regional Sewage, or successor, owner and operator of Dornick Point Sewage Treatment Plant. Its treatment fees are separate and distinct from those imposed by the Authority for sewer rents and system maintenance.

MORTGAGE

The pledge, financing, refinancing or hypothecation of any interest in real property to a lender for value which is evidenced by a mortgage, deed of trust, or other security agreement.

MUNICIPAL SANITARY SEWER SYSTEM

Sewer mains, manholes and laterals from the main sewer at a point to a viewport within the public right of way at or near the boundary line of the serviced property.

OCCUPANT

Any individual or individuals, partnership, association, company, corporation, or municipality, having possession of all or any part of a premises served by the Sanitary Sewer System and using the same for any purpose of residence, business or otherwise, whether as owner, customer, lessee or tenant thereof. Occupant shall comply with the Rules and Regulations of the Authority and, at all times, shall be considered as Agent for the Customer.

ORDINANCE COMPLIANCE OFFICER

Unless the Township of Upper Yoder by Resolution provides otherwise, the Ordinance Compliance Officer shall be the Upper Yoder Township Authority, the "Authority," or its properly authorized officers, agents, engineers, or employees, under these Rules and Regulations.

PERSON

Any natural person, association, partnership, corporation, syndicate, institution, agency, authority, or other entity or the chief executive officer or managing partner or agent of any entity recognized by law as the subject of rights and duties.

PRIVATE LATERAL

The non-municipal piping from the serviced property to the municipal Sanitary Sewer System, including the Building Drain and the Building Sewer.

RULES AND REGULATIONS

Shall mean this document and any amendments or additions hereto, whether or not they are embodied in this or successor documents.

SANITARY SEWAGE

The normal water-carried household and toilet wastes from residences, business buildings, institutions, industrial and commercial establishments, exclusive of storm water runoff, surface water and ground water.

SANITARY SEWER SYSTEM

The Upper Yoder Township system constructed and operated by the Authority, as well as all additions thereto, used for the collection and transportation of Sanitary Sewage.

SELL, TRANSFER OR FINANCING/MORTGAGING

A Sale or Transfer of Real Estate shall include the mortgaging, selling, transferring or assigning of any improved and connected real property located within the Upper Yoder Township Authority Sanitary Sewer System.

SERVICE CONNECTION

The point at which the sewer lateral is connected from the Authority's sewer main line to a point at or near the Customer/Occupant's property line.

SEWER LATERAL

All piping, including the wye and branch from the main sewer line to the curb or property line, as constructed by the Authority or Developer.

SURFACE STORM WATER

Surface water and ground water, including, but not limited to, roof and driveway drainage, basement seepage, and surface and open area drainage.

TRAP

An arrangement in a sewer pipe as a double curve or a "U" shaped section in which liquid remains and forms a seal for preventing the seepage or escape of air or gases through the pipe from behind or below.

UNLAWFUL DISCHARGE

Any roof, surface water or the flow from any groundwater collection system, including any matter or substance determined by the Rules and Regulations to adversely affect the proper operation of the municipal Sanitary Sewer System.

ARTICLE 3 APPLICATION FOR SERVICE

301. The prospective Customer/Occupant, or duly authorized agent thereof, will make application for Sanitary Sewer Service upon the Authority's printed forms (See Applications for Service, Schedules "A" and "B" herein). Said Application, and the Rules and Regulations of the Authority, as amended, constitute the contract between the Customer/Occupant and the Authority. Nevertheless, the acceptance or use of Sanitary Sewer Service at any location by a user, without formal application thereof, obligates the user to these Rules and Regulations and the current rates; and they are bound to same as if they were a Customer/Occupant. The Authority has the right to approve or disapprove the Application for Service.

302. At the time of making application in person at the Authority office, all prospective Customers/Occupants shall provide an official identification and/or a driver's license number. An application may be completed and mailed or completed on the Authority's web site (when it is made available). In such cases, the prospective Customer/Occupant shall include a Photo I.D. and/or driver's license number on the application form.

303. A new Application must be made to the Authority upon any change in the identity of the Customer/Occupant at the premises served. Failure to complete a new Application may result in the Authority discontinuing service until such Application is made and has been approved.

304. An Application is required of the entity assuming responsibility for payment of the bill for service at the service address as noted on the Application. The noted Customer/Occupant should be the person, company, corporation, etc. being provided service. However, in such cases where the property owner, landlord, or other party completes an Application, thereby assuming responsibility for bill payment, the Authority will not recognize the actual end user as a Customer/Occupant.

ARTICLE 4 GUARANTY DEPOSITS

401. If any Customer/Occupant demonstrates a history, as determined by the Authority, of late payment or non-payment relative to their monthly service bill, the Authority will require a deposit equal to \$50 or the total of the highest, three consecutive-month bills during the previous twelve-month period (See Rates and Fees, Schedule "M" herein.).

ARTICLE 5 CAPACITY FEES

501. The Capacity Fee portion of Sanitary Sewer Service charges has been established by the Authority in accordance with the provisions of Pennsylvania Act 57 of 2003. Sanitary Sewer Service from the Authority can be secured only by payment of the appropriate Act 57 Capacity Fee.

502. All prospective Customers/Occupants will pay an equitable charge for their respective share of the Capacity within the Authority's Sanitary Sewer facilities. Capacity Fees will be based upon the Customer's/Occupant's projected sewage flows, calculated in terms of Equivalent Dwelling Units (EDUs).

503. For the purpose of allocating sewer capacity for new residential construction, one EDU is equal to a daily flow of 350 gallons per day, subject to change from time to time by the Pennsylvania Department of Environmental Protection. For new, non-residential construction, the Authority will accept the Customer's/Occupant's estimated or projected sewer flows for the purpose of allocating sewer Capacity, provided said estimates are based on generally accepted engineering standards.

504. Any prospective, residential Customer/Occupant who proposes to utilize a property, where a previous Sanitary Sewer Customer/Occupant had existed, shall be allocated one EDU of Sewer Capacity. In the case of non-residential Customers/Occupants, Sewer Capacity shall be allocated based upon the number of EDUs purchased by the previous Customer/Occupant. Where a previous non-residential Customer/Occupant had existed, but where Act 57 charges did not apply, an EDU value shall be assigned/grandfathered based upon an analysis of past flow records. Purchased or historic EDU Capacity shall be compared to the EDU total requested by the new, prospective Customer/Occupant. Where the proposed flows are less than the purchased or historic, no additional EDU fees will be owing. Conversely, should the prospective Customer's/Occupant's projected request exceed the purchased or historic flows, EDU fees will be owing for the additional Capacity requirements.

505. The Authority will, annually, conduct a Capacity analysis or flow study. Customers/Occupants found to have exceeded their original, purchased or assigned flows for at least one month during any twelve-month period shall be billed additional user fees, based upon their actual flows. Payment shall be due and payable within thirty (30) days of billing for the difference between the previously paid-for or assigned flows and the peak month flows as demonstrated by the Authority's meter reading records during the preceding twelve-month period. The charge for additional flow will be billed at its corresponding EDU value, and at the current rate. Partial EDUs shall be rounded up to the next, whole EDU.

506. In cases where the Capacity paid for by the Customer/Occupant exceeds the actual flows of the Customer/Occupant, the Authority does not refund or rebate any portion of such user charges. Once a particular Capacity is requested and paid for, that portion of Capacity is perpetually allocated to the property served by the Sanitary Sewer Facilities of the Authority. Said Capacity runs with the property and is available for future Customers/Occupants at that location.

507. Act 57 of 2003, amending 53 Pa.C.S. 5601, 5607(d), et seq., Municipality Authorities Act, Capacity Fee (or Special Purpose, etc.) shall be assessed to any Customer/Occupant seeking to establish or reinstate Sanitary Sewer Service to a new or existing, auxiliary structure (garage, shed, pool house, etc.) located on a property, unless the structure is used as a residence or is used to house a commercial/industrial activity producing sewer flows in excess of previously allotted or purchased Capacity in the Sanitary Sewer System.

ARTICLE 6 SERVICE CONNECTION

601. All required sewer Applications must be completed, and all sewer fees paid to the Authority prior to obtaining building permits. It shall be unlawful to release emissions into the Sanitary Sewer System without having first paid the appropriate fees as required. After the Customer/Occupant has completed the required application form (See Application and Agreement for Sewer Service, Schedule "C" herein) and paid the appropriate Connection, Capacity and Collection Fees (See Rates and Fees, Schedule "M" herein), the Authority will schedule the proposed installation at its discretion, but in a timely manner. The Authority will provide the Service Connection to its main line and continue the public Building Sewer (lateral) to a point as near the actual property line as can be determined by conditions in the field.

602. The location of the Sewer Service Connection shall be determined exclusively by the Authority. The Customer/Occupant may request the Service Connection be at a preferred location prior to actual installation. If possible, as determined by the Authority, the Service Connection will be installed at said preferred location.

603. No Service Connections will be installed during any period when street openings are prohibited by State or Municipal regulations, nor at any time when, in the judgment of the Authority, working conditions are unfavorable for the installation either by reason of weather, temperature, soil conditions, or otherwise.

604. Ultimate responsibility for the payment of Connection Fees shall be on the Customer/Occupant of the premises served, whether or not the application is sought by a contractor, developer or others. All remedies for payment to the Authority, including suit, liens and discontinuance of service may be utilized against said Customer/Occupant.

ARTICLE 7 STOPPAGE OF SERVICE

701. Sanitary Sewer Service is subject to Stoppage, with or without notice, resulting from acts of God, or acts or occurrences beyond the control of the Authority. The delivery of Sanitary Sewer Service is subject to the Political Subdivision Tort Claims Act, 42 Pa.C.S. §8501, et seq., as amended.

ARTICLE 8 LINE EXTENSION RULE

801. Sanitary Sewer Service is available only to prospective Customers/Occupants who own property fronting on an existing Authority-owned sewer line, which is sufficient in size and capacity to provide the level of service requested by the Customer/Occupant. It shall be the Authority's sole decision as to whether an existing sewer line is capable of providing the intended service. If a property does not front on any such Authority-owned sewer line, the Customer/Occupant requesting service must pay the cost for extending the Authority collection system (sewer line) as provided for herein.

802. In determining the length of any Line Extension to a bona fide Customer/Occupant, the beginning point of such Extension shall, in all cases, be at the location determined by the Authority, and the terminal point shall be at a point perpendicular to and twenty feet (20') beyond the designated point of entry where the Building Sewer enters or is proposed to enter the structure, except that such terminal point shall not be located within the bounds of a driveway. In such cases the terminal point shall be extended beyond, to avoid ending within any driveway and aprons/approaches. In the event a prospective Customer/Occupant changes the location of the point of entry for the proposed Building Sewer, or the location of the proposed structure intended to be serviced, the terminal point of the Sewer Line Extension shall be field adjusted by the Authority to a point which complies with these Rules and Regulations. The Customer/Occupant requesting such sewer service shall grant unto the Authority a right-of-way with a minimum width of 10 feet, within which the Building Sewer (lateral) shall be installed. Said right-of-way shall be adjacent to the municipal or State or Federal road right of way for the entire frontage along any such roadway, notwithstanding that the required Building Sewer Line Extension may be terminated within such right of way at a point shorter than the total length of the required right of way.

803. No Line Extension to a collection line will be made unless and until the applicant or applicants for such extension have entered into a written contract, which must be approved by the Authority. Such written contract may allow for the Customer/Occupant to install the required Line Extension, as more fully described within the Agreement titled, A-AGREEMENT FOR CONTRACTORS (see Schedule "J" herein), or may provide for the installation of said Line Extension by the Authority, with the costs borne by the Customer/Occupant, as more fully described within the Agreement titled, APPLICATION AND AGREEMENT FOR NEW SEWER SERVICE (see Schedule "C" herein).

804. All sewer mains shall be buried to a depth such that the invert of the main shall be a minimum of four feet (4') below the finish grade. (The Authority reserves the right to determine the maximum allowable depth for sewer mains).

805. All Building Sewer Line Extensions shall be installed in the manner, and with materials, as noted in the SPECIFICATIONS FOR BUILDING SEWER INSTALLATION (Schedule "E" herein), as from time to time amended.

ARTICLE 9 BUILDING SEWER - REFER TO SCHEDULE E, PAGE 5 of 5, and SCHEDULE H, PAGE 4 of 5

901. The Customer/Occupant, or his designee or contractor, must connect to the Sanitary Sewer Lateral provided by the Authority and complete installation of all pipes and fittings extending to the building, structure or appurtenance for which Sanitary Sewer Service is to be provided. All such pipes and fittings are aggregately referred to as the Building Sewer. The cost of the Building Sewer is the exclusive responsibility of the Customer.

902. All fittings and/or adapters required by the Customer/Occupant, along with the actual watertight connection thereof to the Authority's Sewer Lateral, shall be the exclusive responsibility of the Customer/Occupant.

903. The Building Sewer shall be and shall remain the exclusive property of the Customer/Occupant; and any maintenance, replacement, repair, upgrading, etc. shall be the exclusive responsibility of the Customer/Occupant.

904. If a Customer/Occupant wishes to replace the existing Building Sewer, the Customer/Occupant must complete same, at its own cost, under the same terms and conditions in effect at that time governing new Building Sewer lines. No repairs, alterations or additions to the Building Sewer shall be made without first making application to and receiving permission from the Authority. under the terms and conditions that it requires.

905. If a Customer/Occupant wishes to relocate his existing Building Sewer, necessitating a relocation of the Authority's service connection, the Customer/Occupant must pay, in advance, the appropriate Connection Fee as required for new service connections.

906. In all cases, the new Building Sewer or replacement Building Sewer is permitted to service only a single Customer/Occupant. No other property or user is permitted to connect to the Building Sewer.

907. Where two or more Customers/Occupants share a common, single Building Sewer due to a pre-existing condition, any violation of these Rules and Regulations by one Customer/Occupant shall be deemed a violation by all those provided Sanitary Sewer Service through said common Building Sewer. The Authority may take such action against all as could be taken against a single Customer/Occupant. The Customer/Occupant who is not in violation of these Rules and Regulations may be given reasonable opportunity to connect his Building Sewer to the Authority's Sanitary Sewer System.

908. Any Customer/Occupant who shares a common, single, Building Sewer with another Customer/Occupant, due to a pre-existing condition, may request the Authority provide a new, separate service connection. If the Customer/Occupant making such request installs a new, separate Building Sewer (per Authority specifications), the Authority will provide the new, service connection at the expense of the Customer/Occupant.

909. When a single structure is so constructed to allow for separate occupancy and possible separate ownership (such as a Double House, Townhouse, etc.) separate sewer service connections and a separate Building Sewer shall be required for each unit requiring Sanitary Sewer Service. Waiver of this policy is at the sole discretion of the Authority.

910. Where a single structure is so constructed to allow for separate occupancy but the layout does not lend itself to possible separate ownership (such as a Commercial Office Building, Apartment Building, Retail/Commercial/Industrial Complex etc.), the Authority may allow the installation of a single service connection and a single Building Sewer.

911. Building Sewer Specifications:

911-A. No Building Sewer shall be within three feet of any open excavation or vault, unless such installation plan shall have been previously authorized and approved by the Authority, as evidenced by its written permission.

911-B. The Building Sewer shall not be installed across the property of a third party in order to access an Authority-owned sewer line (See Line Extension Rule). The Authority may waive this requirement on a case by case basis in extenuating circumstance.

911-C. The Building Sewer shall not occupy the same trench with any telephone, electric, cable TV wire, or any other facility, other than the water line serving the property. Where the Building Sewer and the water service line do occupy the same trench, the installer must take measures to maintain a physical separation of at least 18 inches between those facilities.

911-D. No connection to the Building Sewer of a cesspool, privy, vault, septic tank, cistern or other depository is allowed. Such depositories, at the time of connection of the Building Sewer to the Sanitary Sewer System, must be disconnected, and inlet/outlet pipes capped with watertight seals. The Customer/Occupant shall comply with all applicable Federal, State and Local laws, ordinances, resolutions and regulations pertaining to disposition of septic tanks.

911-E. The Building Sewer shall be constructed with the materials and in the manner approved by the Authority, as amended from time to time. Persons desiring to connect to the Authority's Sanitary Sewer System should check with the Authority prior to purchase of material for the current, approved specifications and materials (See Specifications for Building Sewer Installation).

911-F. No storm or ground water is permitted to enter into the Building Drain or into the Building Sewer. As such, all piping, buried or to be buried, both inside and outside the foundation wall, must be tested for water tightness and such testing must be supervised and approved by a representative of the Authority.

912. Additional Building Sewer Specifications for Commercial and Industrial Connections:

912-A. Any prospective commercial or industrial Customer/Occupant may, at the discretion of the Authority, be required to install a suitable manhole or manholes within the Building Sewer to facilitate observation, sampling and measurement of the combined flow of wastes from the premises. Such manholes shall be accessible and safely located and shall be constructed in accordance with plans approved by the Authority (See Specifications for Building Sewer Installation). Manholes shall be installed and maintained in a safe condition at all times by the Customer/Occupant of the premises, and at his own expense.

912-B. Any current or prospective commercial or industrial Customer/Occupant generating grease, oil and fats which may be released into the Authority's Sanitary Sewer System shall be required to install, with the prior approval of the Authority, a properly-sized grease and/or oil separation device, commonly referred to as a Grease Trap, within the Building Sewer. Said Grease Trap shall be designed, constructed, installed and routinely maintained so as to keep the grease content of Sanitary Sewage leaving the premises to less than 100 parts per million by weights.

ARTICLE 10 INSPECTION AND TESTING OF NEW CONNECTIONS

1001. Before connection to the Authority's Sanitary Sewer System, all buried sewer piping, both outside and inside the foundation wall, must be inspected by an authorized representative of the Authority, who shall certify in writing that the installation is in conformance with the Authority's Rules and Regulations, that no roof, surface, foundation or underground drainage is connected to the Sanitary Sewer System and that the Authority's requirement for water tightness has been met.

1002. Prior to Inspection and Testing by the Authority of the Building Drain and Building Sewer, a plumbing diagram shall be provided to the Authority. Such diagram shall show the piping layout of all buried sewer piping, including piping buried below basement floor level. The Customer's/Occupant's plumbing diagram shall include the pipe size, material, and lengths of pipe between fittings.

1003. All work, equipment and materials necessary to provide for and perform Inspection and Testing of a new Building Sewer and Building Drain shall be the responsibility of the Customer/Occupant or his or her designee or contractor. The representative of the Authority shall only supervise such Testing and shall make the determination as to correct Testing procedures and the passing or failing results of such Test.

1004. Upon successful completion of the Inspection and Testing, the Representative of the Authority shall provide written approval and acceptance by signing and dating the completed Certificate Of Compliance for Sanitary Sewer Pressure Testing [see Schedule "D" herein]. A copy of such form shall be provided to the prospective Customer/Occupant or designated agent. No Customer/Occupant shall be connected or remain connected to the Sanitary Sewer System without securing written authorization by signature of an Authority representative.

ARTICLE 11 INSPECTION AND TESTING OF EXISTING CONNECTIONS/WITHOUT SALE, FINANCING OR TRANSFER PENDING

1101-A. No repairs, alterations or additions to any Building Drain or Building Sewer which is connected to the Sanitary Sewer System shall be made unless the Customer/Occupant desiring to make the same shall make application to and purchases a permit from the Authority. When the permit is issued and the work is completed, the Customer/Occupant shall comply with Section 1107 hereunder.

1101-B. i. Duly authorized employees or representatives of the Authority shall have the right to enter on the premises of any person, firm, corporation or other entity connected to the Sanitary Sewer System for the purpose of inspection, supervision, measurement, sampling, testing, inspection of connections or fixtures, for a disconnection of service, for enforcement of these Rules and Regulations and for other such purposes for the protection of public health and property and the effective, orderly operation of the Sanitary Sewer System. Authority employees or representatives shall bear proper credentials and identification and display the same when requested. By virtue of being connected to and receiving service from the Authority's Sanitary Sewer System, each Customer/Occupant receiving said services acknowledges and authorizes Authority employees or representatives to enter upon the subject premises for the aforesaid purposes, including supervising pressure testing of all buried and under slab piping of the premises.

ii. In the case of the physical disconnection of service at the Building Drain or Building Sewer for any reason, including demolition of the serviced property, the Customer/Occupant or his , her or its agent, shall not only make Application for a permit from the Township and or Authority, but shall be prohibited from capping off the connection without the prior approval of the duly authorized Township employee or Authority representative who shall inspect the same prior to any backfilling or physical concealment thereof.

1102. Closed Circuit Televised Testing (CCTV), or video inspection, may be performed for the purpose of locating a line obstruction or blockage. If it is determined that the location of such obstruction is within the Customer's/Occupant's Building Sewer or Building Drain, the cost of the video inspection and all work necessary to remove such obstruction, including work performed by the Authority or by any subcontractor, shall be the responsibility of the Customer/Occupant.

1103. The Authority may perform Closed Circuit Televised Testing (CCTV), or video inspection, to determine or expose the release of grease, oil or fats into the Authority's Sanitary Sewer System. In the event of a blockage in the Authority's system caused by the failure of an establishment to provide or maintain a Grease and/or Oil separation device within its Building Drain or Building Sewer (See Section 912-B), the cost of correcting, repairing and eliminating such Sanitary Sewer System blockage shall be the responsibility of the Customer/Occupant causing the back up or blockage.

1104. The Authority may perform Closed Circuit Televised Testing (CCTV), or video inspection, to document the existence of Inflow and Infiltration (I&I) entering the Sanitary Sewer System through a Customer's/Occupant's Building Drain/Building Sewer.

1105. Any Customer/Occupant found to be in violation of the Authority's Rules and Regulations, by allowing any quantity of Inflow and Infiltration into the Sanitary Sewer System, shall be required to bring all buried pipelines into compliance. The Customer/Occupant shall be notified, by both **regular mail** and **certified mail**, to correct said condition.

1106. Within thirty (30) days of the date of the notification, a Schedule of Repairs must be presented to the Authority. The Schedule shall include a signed contract with a prospective contractor or a signed guarantee by the Customer/Occupant, containing the specific date of repair. The scope of work must be significant, as determined by the Authority. All such repairs must be completed, and the system brought into compliance, within five (5) months from the date of the original notification.

1107. Customer/Occupant must prove compliance at the time of inspection by either an air or water pressure test as defined by Section 312 of the International Plumbing Code, as the same is amended and contained in the Pennsylvania Uniform Construction Code, as amended, and contained herein. If a portion(s) of the Customer's/Occupant's system fails to meet compliance standards, additional repairs must be completed and tested until the Authority determines that the entire system is in compliance within the original five (5) month time frame.

1108. The Authority Sanitary Sewer System is currently under comprehensive rehabilitation for the elimination of inflow and infiltration, with a goal of achieving a watertight Sanitary Sewer System. When each segment of the system rehabilitation is completed, the Customer/Occupant of the property within the completed segment shall be given 30 days' notice by the Authority that said property must pass an air or water pressure test, proving that the Building Drain and Building Sewer are watertight. If a portion of the Customer's/Occupant's Building Drain or Building Sewer fails to meet compliance standards, additional repairs must be completed until the Customer/ Occupant's entire system has been determined to be in compliance within a five (5) month time frame. Subject to the provisions hereunder, watertight compliance must be proven within five (5) months of the Customer's/Occupant's receipt of sector notice for air or water pressure testing.

1109. Failure to bring all buried pipelines into compliance within the five (5) month time frame shall be deemed a violation of these Rules and Regulations.

1110. In cases where complying with this Regulation prior to closing on a pending sale would cause an undue hardship, the Customer/Occupant may request a hardship extension and a Time Extension Agreement For Sewer Compliance not to exceed sixty (60) days from the date of issue which may be granted for pressure testing at the sole discretion of the Authority, on a case-by-case basis. Application for said extension may be made at the Authority office by: a. completing the Time Extension Agreement; b. providing proof of a bona-fide contract which states the contractor or Customer/Occupant will perform the work required to bring the property into compliance; and c. providing proof that one hundred ten percent (110%) of the funds required to bring the property into compliance have been escrowed or otherwise set aside to pay for the work needed; and d. if applicable, providing proof of real estate sales agreement which contains provisions identifying the parties' obligations concerning Sanitary Sewer compliance. Applications for hardship extensions shall be made on the forms provided hereinafter as Schedule "F" for residential properties and Schedule "G" for commercial properties. The terms and conditions therein are a component part of the Rules and Regulations and shall be binding on the Applicant Owner/Transferor or Buyer/Transferee or Mortgagor.

ARTICLE 12 SEWER COMPLIANCE AT SALE, TRANSFER, ASSIGNMENT AND MORTGAGE/FINANCING REGULATIONS

1201. The following regulations are applicable to both parties of a real estate transfer, both before and after the transfer of the serviced property (the Authority reserves the right from time to time by Motion, duly carried, to temporarily suspend the Rules and Regulations requiring pressure testing for mortgages and financings).

1202. TRANSFER OF PROPERTY

1202-A. Required Air and Water Pressure Testing.

The Authority requires air or water pressure testing and inspection within its Township Sanitary Sewer System for the purpose of discovering or locating the inflow or surface, storm or ground water, or other unlawful connection, into the Upper Yoder Township Authority Sanitary Sewer System. The representatives of the Authority are required to be present at the time the approved third-party contractor or the Customer/Occupant, if qualified for the testing, performs the air or water pressure testing. All testing and supervisory fees shall be at the expense of the Customer/Occupant of the property which is connected to the Sanitary Sewer System. Customer/Occupant shall also grant access to the representatives of the Authority for said supervision of the third-party contractor or the Customer/Occupant, if qualified for the testing, who is performing the air or water pressure testing. It shall be unlawful to refuse access to property for purposes of said testing.

i. Proof of Compliance on Sale, Transfer, Assignment or Mortgage Financing

It shall be unlawful for person to sell, transfer, assign or mortgage any improved and connected real property located within the Upper Yoder Township Authority Sanitary Sewer Collection System without having obtained and, in the case of a sale, without having delivered to the buyer, transferee or assignee, at or prior to closing, a Certificate Of Compliance for Sanitary Sewer Pressure Testing for the property being sold, transferred or assigned.

ii. All buried and under-slab Sewer piping, both outside and inside the foundation wall, (most often identified as the Building Drain and Building Sewer), be Pressure Tested for water tightness. Such Testing must be supervised and approved by the Authority. Any sale, transfer or financing of Property, as previously defined, without having successfully passed a Test and/or without first obtaining a Certificate Of Compliance for Sanitary Sewer Pressure Testing from the Authority, shall be in violation of the Authority's Rules and Regulations and shall be subject to non-compliance fees as hereinafter set forth.

iii. A Transfer or a mortgage of Property is not exempt from Sewer Testing whether or not the Customer/Occupant can provide documentation that the Property successfully passed an air or water pressure test, as set forth in Section v. below. The Customer/Occupant shall provide any documentation which is required by the Authority, including access to perform visual inspections as are deemed necessary by the Authority to establish that said piping has not been altered in any way since the prior Testing and that no excessive flows exist which would otherwise demonstrate an Inflow and Infiltration violation.

iv. The Customer/Occupant of Property shall install or cause to be installed, a viewport (if none exists) in accordance with the Authority's specification for purposes of the aforesaid Testing. **If a viewport already exists on the Property, but it is not visible or easily accessible, the Customer/Occupant shall expose said viewport. All of the foregoing shall be at the expense of the Customer/Occupant.** Existing viewports shall not be required to be upgraded to current standards, unless said viewport is being replaced as part of repair work to be performed as a result of the Test results.

v. Approved Testing Methods:

Acceptable testing methods are provided in §312 of the International Plumbing Code (IPC), as the same are amended and contained in the Pennsylvania Uniform Construction Code, as amended and contained herein, and which are incorporated herein by reference.

1. Testing by water wherein all buried and under-slab piping (both inside and outside the foundation) is filled with water and a temporary water column is introduced to a minimum of ten (10) feet of head to the highest portion of the buried and under-slab piping, with no water loss observed during a fifteen (15) minute period. In the event the serviced property passes pressure testing, the Authority Representative shall issue a Certificate of Compliance, Sanitary Sewer Pressure Testing.

2. Testing by air wherein all buried and under-slab piping is pressurized with air to a minimum of five pounds per square inch (5 psi) and thereafter held for a period of fifteen (15) minutes with no noticeable pressure drop. In the event the serviced property passes pressure testing, the Authority Representative shall issue a Certificate of Compliance, Sanitary Sewer Pressure Testing.

3. ANY CERTIFICATE OF COMPLIANCE ISSUED FOR PRESSURE TESTING SHALL BE VALID FOR A PERIOD OF FIFTEEN (15) YEARS, UNLESS THE BUILDING IS SOLD, TRANSFERRED OR REFINANCED, OR UNLESS THE BUILDING DRAIN AND BUILDING SEWER OF THE SERVICED PROPERTY IS ALTERED, WHETHER INTENTIONALLY OR BY NATURAL OCCURRENCE, WITHIN SAID PERIOD, OR EXCESS FLOWS EXIST WHICH WOULD DEMONSTRATE AN INFLOW OR INFILTRATION VIOLATION, WHEREUPON, TESTING, INSPECTIONS OR METERING WILL BE REQUIRED. THE OWNER/OCCUPANT SHALL BE REQUIRED TO ELIMINATE THE RESULTANT INFLOW AND INFILTRATION OR SHALL BE SUBJECT TO FINES, PENALTIES AND SUMMARY PROSECUTION IN VIOLATION OF THESE RULES AND REGULATIONS AND SHALL BE REQUIRED TO REAPPLY FOR A CERTIFICATE OF SANITARY SEWER COMPLIANCE.

vi. Requests for inspection or supervision of the Pressure Testing must be made a minimum of seventy-two (72) hours in advance of the requested time. The Authority will allow a maximum of one (1) hour per Test, and the supervision shall be for the actual Test itself, not for preliminary hook up or other work which precedes the actual Test. In the event that the Property does not pass the initial Test, the Authority will charge a fee, paid in advance at the Authority office, for each and every re-Test that is necessary (See Rates and Fees, Schedule "M" herein).

It is the intent of this Regulation that the Authority Inspector is scheduled only to supervise a passing Air or Water Pressure Test. The Authority inspector shall make the sole determination as to when the actual Testing period commences and thereafter when the fifteen (15) minute duration of the Test has expired. Upon successful completion of the Testing, the inspector shall signify his/her approval by affixing his/her signature and dating the completed "Certificate of Compliance for Sanitary Sewer Pressure Testing."

1202-B. Application for and Certificate of Compliance for Sanitary Sewer Pressure Testing.

At least twenty-one (21) days prior to the date of mortgage settlement, closing, transfer or assignment of any improved real property located within the Township Sanitary Sewer System, the owner, seller, mortgagor, transferor, transferee, assignor, assignee or its agent shall submit to the Authority an Application for and Certificate of Compliance for Sanitary Sewer Pressure Testing. The Application shall be available upon request from the Authority's Secretary. The fee for filing the completed Application For and Certificate of Compliance for Sanitary Sewer Pressure Testing shall be established by the Authority from time to time by Resolution.

1202-C. Issuance of Certificate of Compliance.

i. If the Application for and Certificate of Compliance for Sanitary Sewer Pressure Testing is properly filed with the Authority with the designated filing fee, which indicates that there are no unlawful connections to the Sanitary Sewer System, then the Authority shall issue the Certificate of Compliance for Sanitary Sewer Pressure Testing within ten (10) days of application therefore.

ii. If the air or water pressure test reveals the existence of one or more unlawful connections to the Sanitary Sewer System, the Authority shall not issue the Certificate of Compliance for Sanitary Sewer Pressure Testing until the unlawful connections have been removed by a qualified contractor or by the Customer/Occupant, to the satisfaction of the Authority. When there are no longer any unlawful connections to the Sanitary Sewer System from the property to be mortgaged, sold, assigned or transferred, the Authority will issue the Certificate of Compliance for Sanitary Sewer Pressure Testing.

iii. In cases where complying with this Regulation prior to closing would cause an undue hardship, the Customer/Occupant may request a hardship extension and a Time Extension Agreement For Sewer Compliance not to exceed sixty (60) days from the date of closing which may be granted at the sole discretion of the Authority, on a case-by-case basis. Application for said extension may be made at the Authority office by: a. completing the Time Extension Agreement; b. providing proof of a bona-fide contract which states the contractor or Customer/Occupant will perform the work required to bring the property into compliance; c. providing proof that the one hundred ten percent (110%) of the funds required to bring the property into compliance have been escrowed or otherwise set aside to pay for the work needed; and d. providing proof of real estate sales agreement which contains provisions identifying the parties' obligations concerning Sanitary Sewer compliance. Applications for hardship extensions shall be made on the forms provided hereinafter as Schedule "F" for residential properties and Schedule "G" for commercial properties. The terms and conditions therein are a component part of the Rules and Regulations and shall be binding on the Applicant Owner/Transferor or Buyer/Transferee or Mortgagor.

ARTICLE 13 DETRIMENTAL WASTES

1301. The Sanitary Sewer System governed by these Rules and Regulations is primarily for the collection and discharge of Sanitary Sewage. No Customer/Occupant shall discharge into the System any waste deemed harmful to the System or dangerous to the health and life of operating personnel and the public. The types of sewage prohibited by the Authority from discharge to the Sanitary Sewer System shall include but are not limited to the following substances and shall be pretreated as required hereunder:

- Mineral acids, waste acid, pickling or plating liquors from the pickling or plating of iron, steel, brass, copper or chromium, or any other dissolved or solid substances which will endanger health or safety, interfere with the flow in sewers, attack or corrode sewers or sewage structures or equipment or otherwise interfere with the operation of the Sanitary Sewer System of the Authority.
 - Cyanides or cyanogen compounds capable of emitting hydrocyanic gas upon acidification.
 - Fats, entrails and the like from meat processing plants, rendering plants and similar industries and establishments.
 - Gas tar, phenols, residues from petroleum storage, refining or processing, fuel or lubricating oil, gasoline, naphtha, benzene or explosive or inflammable liquids, solids or gases.
 - Ashes, cinders, sand, mud, lime or acetylene sludges, straw, shavings, metal, glass, rags, feathers, tar, plastics, wood, sawdust, paunch, manure, hair, hides, dead animals, spent mash and grain, pulp from food processing, water or wastes containing grease in excess of 100 parts per million, or any other solids or viscous substances capable of causing obstruction to the flow in sewers or other interference with the proper operation of the sewers of the Authority.
 - Sludges or other materials from septic tanks or similar facilities or from sewage or industrial waste treatment plants or from water treatment plants.
 - Garbage, or solid or viscous substance in quantities, either by itself or in combination with other wastes, which are capable of obstructing the flow of sewer works or treatment facilities, including, but not limited to, the following: syringes, sanitary napkins, wipes, towels, bandages, and diapers of every type, latex gloves or similar protective devices, ashes, cinders, sand, mud, straw, hair, shavings, metal, glass, rags, feathers, tar, grass clippings, asphalt, seafood shells, cloth, plastic, wood, chemical residues, brewing or distilling slops, spent grain or hops, whole blood, meat trimmings and wastes, animal paunch contents, hide, hair, offal, fish or fowl heads or parts, entrails, lard, tallow, baking dough, cannery waste bulk solids, or paper or metal utensils, plastic or paper containers either whole or ground; except properly shredded and allowable garbage in a private dwelling, apartment building, hotel, commercial restaurant or retail food store, resulting from the proper use of a garbage grinder or disposer of a type approved by the Authority and maintained in good operating condition; provided, however, that no retail food store shall operate more than one grinder or disposer which shall be not greater than three horsepower in size and, when so required by the Authority, shall be equipped with an approved water meter and limited use to the consumption of an average of not more than 1,500 gallons of waste per day.
- Every building, structure or premises used or occupied by any sewer user where any commercial or industrial operations are conducted or permitted which result in the discharge into the sewer system of any products, waste products, or other substances, matter, or liquid in the manner and to the extent prohibited in this Section shall be required to remove pollutants before they are discharged with Authority approved devices or systems used for the storage, treatment, recycling or reclamation of the waste, and shall be equipped with an adequate and suitable pretreatment facility, oil separator, grease trap, filter or other interception device installed in such a manner that the product, waste products, or other substances, materials or liquid herein set forth will not flow into or be discharged into the sanitary sewer system. The oil separator, grease trap, filter, or other interceptor or other pretreatment facility shall be approved by the Authority and adequately maintained and regularly documented as an approved pretreatment program by the Owner/Occupant, and shall be readily accessible for inspection by the Authority at any time to ensure its proper operation.
- Water or wastes having a pH lower than 5.5 or higher than 9.0, or having any other corrosive property capable of causing damage or hazard to structures, equipment or personnel of the Authority.
 - Biologic and biohazard waste, unused medicines, whether prescriptive or over the counter and contained as a solid or in liquid form including application paraphernalia.

1302. Any prospective Customer/Occupant who proposes to discharge industrial or process wastes into the Sanitary Sewer System, or any Customer/Occupant who proposes to change its method of operation so as to alter the types of wastes previously discharged, shall notify the Authority and the appropriate Treatment Facility in order that testing may be conducted to determine whether such wastes may have a harmful effect on the Authority's System or on the Sewage Treatment Facility. In such event, the Customer/Occupant shall comply with the provisions of Section 1301 above.

1303. The Authority's Sanitary Sewer System serves to transport Sanitary Sewage and industrial wastes to the Sewage Treatment Facility owned by the Johnstown Redevelopment Authority which has its own Rules and Regulations; and Customers/Occupants are advised that they are also bound by and must follow the Rules and Regulations of the Treatment Facility to which their sewage is transported by the Authority.

ARTICLE 14 DEDUCTION METERS

1401. A second or "deduction" meter may be requested by a Customer/Occupant to meter that amount of water that does not eventually discharge into the Authority's Sanitary Sewer System. After the Authority has approved the Customer's/Occupant's request and the location of said deduction meter, the Customer/Occupant is required to complete the appropriate application and to complete the necessary plumbing arrangements at his expense. Typical uses of a deduction meter are the filling or refilling of swimming pools, watering lawns, washing cars, etc. Water used through a deduction meter will be deducted from the total water as registered by the primary meter. The amount registered by the deduction meter will be charged only according to the water rate schedule. Water registered by the primary meter, less the deducted gallonage, will be charged according to both the water rate and sewer rate schedules.

1402. No meter shall be installed without the prior approval of the Authority. Any meter installed shall also be approved by the Greater Johnstown Water Authority for purposes of billing program compatibility.

1403. Customers/Occupants who choose not to install a deduction meter to quantify the amount of water that does not eventually discharge into the Authority's Sanitary Sewer System, may be afforded a one-time credit for sewer charges on the initial fill-up of newly-constructed swimming pools. The amount of the credit will be determined solely by the Authority. The Authority shall maintain a listing of those properties that have received the one-time credit, and no further credit(s) will be issued.

ARTICLE 15 BILLS AND PAYMENT

1501. Bills as rendered for any indicated period of service—special, monthly or quarterly—will show the proper charge, as determined by the applicable Rate Schedule (see Schedule "M" herein), the amount of any abatement or deduction allowed, any fee or additional charge due and any payment under the Rules and Regulations. Bills shall be considered as duly rendered when delivered at, or mailed to, the recorded address of the Customer/Occupant as provided by the Customer/Occupant for that purpose or, otherwise, to the premises serviced. Non-receipt of a bill shall never constitute a waiver thereof. The Authority will, upon request, issue a facsimile bill to Customers/Occupants with lost or misplaced bills; but no claim for exemption from assessment charge for delayed payment will be entertained or allowed for any reason whatsoever. Bills are prepared and mailed at approximately the same time quarter annually. Any Customer/Occupant who fails to receive a bill during any month, or who misplaces or loses said bill is required to contact the Authority office to ascertain the amount of that month's bill. Payment of all bills must be received at the Authority office on or before the date specified. Those received later will be subject to the appropriate late charges, which will be applied with the following quarter's billing.

1502. In case the Authority has been unable for any reason to obtain the meter reading at the regular reading period, the Authority reserves the right to bill the Customer/Occupant for an estimated flow so noted on the bill. This estimated flow shall be deducted from the recorded flow at the subsequent meter reading period, and the bill for the subsequent period shall be rendered accordingly.

1503. If the Authority has been unable to obtain an actual meter reading during any six (6) month period, water service may be discontinued, after proper notice, until the property Customer/Occupant provides access for Authority personnel to obtain a meter reading.

1504. When vacating a premises, the Customer/Occupant shall notify the Greater Johnstown Water Authority and this Authority at least one business day in advance of the date to discontinue service. In such case, the meter will be read during normal business hours, the bill rendered accordingly and the account closed as of that date. At the option of the Authority when discontinuing service, the meter may be removed.

1505. Payment for special or temporary use shall be payable upon receipt of invoice.

1506. Any invoice for repairs or replacement of any Authority-owned facility damaged by any Customer/Occupant will be due ten (10) days after presentation of the invoice. Failure to pay an invoice within the allotted time may result in termination of water service until payment has been rendered. When appropriate, invoices for such repairs or replacement shall be rendered in the name of the property Customer/Occupant and mailed to the address of the Customer/Occupant of record.

1507. Any Customer/Occupant who re-enters the service area and who owes an unpaid previous balance from water and/or sewer service to the Authority, must pay the outstanding balance (and any late fees or non-compliance fees) in full before service will be initiated.

1508. A service charge (see Rates and Fees, Schedule "M" herein) will be imposed for each check returned unpaid. This fee may be waived, at the discretion of the Authority, when extenuating circumstances exist.

1509. If payment of a quarter annual sewer bills is not received by the sooner of ninety (90) days from the date of billing or the issuance of the following quarter annual bill, then Customer/Occupant shall be given a ten (10) day deadline for payment of the delinquency in full. Failure to make payment will result in the Authority discontinuing the supply of water to the benefitted property, and any time thereafter, until all charges, including Service Restoration Fees, non-compliance fees and interest, are paid (see Rates and Fees, Schedule "M" herein). Such action by the Authority does not preclude or stay collection of the charges by process at law or in equity as hereinafter provided.

ARTICLE 16 ENFORCEMENT

1601. Any violation of these Rules and Regulations is hereby declared to be a summary offense in accordance with Section 5607 (d) 17 of the Municipality Authorities Act, as amended, and shall be punishable by a fine of up to Three Hundred Dollars (\$300.00), and up to ninety (90) days imprisonment, for each offense. Each and every day that a violation of these Rules and Regulations exists shall constitute a separate and distinct offense.

1602-A. The Township of Upper Yoder has adopted Ordinances governing the rendering of Sanitary Sewer Service. Customers using the Authority's Sanitary Sewer System are advised that they are likewise subject to the Township Ordinances governing the delivery of Sanitary Sewer Service and treatment, whether or not specifically set forth herein. Where there is a conflict between these Rules and Regulations or the Upper Yoder Township Ordinances, these Rules and Regulations shall take precedent.

1602-B.

i. Customers/Occupants who receive notification that pressure testing is required and who have not obtained a Certificate Of Compliance for Sanitary Sewer Pressure Testing within (12) months from the date of the Notice To Comply or from the grant of hardship extension shall be assessed monthly non-compliance fees for each connection to the municipal Sanitary Sewer System. The non-compliance fees for refusal or failure to comply shall be as follows:

FOR SINGLE FAMILY DWELLINGS:	
1 – 12 months violation:	\$150 per quarterly billing
13 - 24 months violation:	\$225 per quarterly billing
25 months and beyond violation:	\$300 per quarterly billing

FOR CUSTOMERS OTHER THAN SINGLE FAMILY DWELLINGS:
(Multi-Family, Industrial and Commercial)

1 – 12 months violation:	\$150 per quarterly billing per EDU
13 - 24 months violation:	\$225 per quarterly billing per EDU
25 months and beyond violation:	\$300 per quarterly billing per EDU

These non-compliance fees may be amended from time to time by Resolution duly passed.

The hereinabove enforcement procedures are cumulative and not exclusive of each other.

ii. These Rules and Regulations may also be enforced by the Authority through the Pa. Municipal Claim and Tax Lien Law Act of May 16, 1923 as Amended or in an action in equity brought in the Court of Common Pleas of Cambria County, Pennsylvania; to the extent these Rules and Regulations are more particular or conservative than the prior Upper Yoder Township Ordinances or Rules and Regulations, these Rules and Regulations shall be controlling.

1603. Any violation of these Rules and Regulations including, but not limited to, refusal to comply with Sanitary Sewer passing pressure testing may also result in discontinuation of water service as provided hereunder.

ARTICLE 17. DISCONTINUATION OF SERVICE.

1701. The Authority reserves the right to prevent the discharge of Inflow and Infiltration and wastes which do not fall within the parameters of the above-mentioned Rules and Regulations and Ordinances by—

- prohibiting connection to the Sanitary Sewer System.
- disconnecting Building Drains or compelling discontinuance of the use of the Sanitary Sewer System, both at the Owner/Occupant's expense.
- compelling pretreatment of industrial wastes at the Owner/Occupant's expense.

1702. The Authority may discontinue water service upon thirty (30) days' notice for any of the following reasons:

- For violation of Rules and Regulations of the Authority as they relate to refusal or failure to perform required pressure testing or related Ordinances of the Township of Upper Yoder as they relate to illegal connections or discharge into the municipal Sanitary Sewer System.
- For refusal of reasonable access to property for purpose of inspection.
- For failure to pay sewer connection fees, inspection fees, rental fees and any other charges due and owing to the Authority.

1703. Service will be restored under proper application when the conditions under which such service was discontinued are corrected and upon the payment of all proper charges provided in the Schedule of Rates (see Schedule "M" herein) of the Authority due from the Applicant.

ARTICLE 18. GENERAL SUMMARY OF PROVISIONS

1801-A. The Authority requires air or water testing (Second 312 of the International Plumbing Code) of Building Drains and Building Sewers (laterals) which are connected to its sanitary sewer system, upon the sale, transfer or financing of any property.

1801-B. As the Authority repairs or replaces its Sanitary Sewer System, Customers/Occupants shall be given notice that the serviced property shall be, at the election of Customer/Occupant, either air or water pressure tested in conformance with Section 312 of the International Plumbing Code in accordance with these Rules and Regulations.

1801-C. No surface, storm or ground waters are permitted to inflow or infiltrate into the Authority's Sanitary Sewer System, and Customer/Occupant shall bear the cost to comply with these Rules and Regulations.

1801-D. No repairs, alterations or additions to any Building Drain or Building Sewer (lateral) shall be made without proper application to the Authority and without proper inspection or supervision by an Authority representative for Rules and Regulations compliance.

1802. The Authority reserves the right at all times, after due notice sent to the Owner's last-known address, to request the Greater Johnstown Water Authority, its successor and assigns, to shut off water service to the property that benefits from the sanitary sewer system for nonpayment of sewer connection, inspection, and rental fees and charges or for neglect or refusal to comply with the Rules and Regulations of the Authority. The Authority reserves the right to disconnect non-compliant Building Drains and Sewers from its Sanitary Sewer System at the owner's cost and expense.

1803. Failure to receive a bill shall not exempt any customer from obligation to pay connection, inspection and rental fees, and charges. The presentation of a bill to the customer is only a matter of accommodation and not a waiver of this Rule.

1804. Where special services are required, the Authority shall fix the rate therefore and the cost of service shall be paid by the owner of the serviced property at the time the application is submitted and before the service is granted and performed.

1805. The Authority shall establish, from time to time, by resolution -assessments, rental and connection charges, inspection fees, etc., which shall be paid Customer/Occupant of the sanitary sewer collection system for the costs of repair, restoration, operation, maintenance, inspection and supervision of the Upper Yoder Township sanitary sewer collection system.

1806.-A. No repairs, alterations or additions to any Building Drain or Building Sewer which is connected to the Sanitary Sewer System shall be made unless the Customer/Occupant, desiring to make the same, shall make application to and purchases a permit from the Authority. When the permit is issued and the work is completed, the Customer/Occupant shall comply with Section 1107 hereinabove.

1806-B. Duly authorized employees or representatives of the Authority shall have the right to enter on the premises of any person, firm, corporation or other entity connected to the Sanitary Sewer System for the purpose of inspection, supervision, measurement, sampling, testing, inspection of connections or fixtures, for a disconnection of service, for enforcement of these Rules and Regulations and for other such purposes for the protection of public health and property and the effective, orderly operation of the Sanitary Sewer System. Authority employees or representatives shall bear proper credentials and identification and display the same when requested. By virtue of being connected to and receiving service from the Authority's Sanitary Sewer System, each Customer/Occupant receiving said services acknowledges and authorizes Authority employees or representatives to enter upon the subject premises for the aforesaid purposes, including supervising pressure testing of all buried and under slab piping of the premises and.

1807. ANY CERTIFICATE OF COMPLIANCE ISSUED FOR PRESSURE TESTING SHALL BE VALID FOR A PERIOD OF FIFTEEN (15) YEARS, UNLESS THE BUILDING DRAIN AND BUILDING SEWER OF THE SERVICED PROPERTY IS ALTERED, WHETHER INTENTIONALLY OR BY NATURAL OCCURRENCE, UNLESS THE BUILDING IS SOLD, TRANSFERRED OR FINANCED WITHIN SAID PERIOD, OR EXCESS FLOWS EXIST WHICH WOULD DEMONSTRATE AN INFLOW OR INFILTRATION VIOLATION, WHEREUPON, TESTING, INSPECTIONS OR METERING WILL BE REQUIRED. THE OWNER/OCCUPANT SHALL BE REQUIRED TO ELIMINATE THE RESULTANT INFLOW AND INFILTRATION OR SHALL BE SUBJECT TO FINES, PENALTIES AND SUMMARY PROSECUTION IN VIOLATION OF THESE RULES AND REGULATIONS AND SHALL BE REQUIRED TO REAPPLY FOR A CERTIFICATE OF SANITARY SEWER COMPLIANCE.

1808. If any section, paragraph, sub-section, clause, or provision of these Rules, Regulations and Rates shall be declared by a court of competent jurisdiction to be invalid, such decision shall not affect the validity of these Rules, Regulations and Rates as a whole or any other part hereof.

1809. The Authority reserves the right to change or amend from time to time these Rules, Regulations and Rates, Fees and Penalties.

UYTA
Upper Yoder Township
Authority

110 Sunray Drive, Suite 1
Johnstown, PA 15905
Phone: (814) 255-5243
Fax: (814) 255-1805

A PA Municipal Corporation

www.upperyodertownship.org

OFFICE USE ONLY	
Acct. No. _____	Book _____
CR _____	PN _____
Pressure Test Needed _____	
Walk Thru Needed _____	

EXISTING SERVICE

APPLICATION FOR SERVICE - RESIDENTIAL

DATE OF APPLICATION _____ SERVICE START DATE _____ OWN _____ RENT _____

CUSTOMER NAME _____

SERVICE ADDRESS _____ MAILING ADDRESS _____
(If different from service address)

CITY _____ STATE _____ ZIP _____ CITY _____ STATE _____ ZIP _____

PHONE () _____ - _____ CELL () _____ - _____ FAX () _____ - _____

DRIVERS LICENSE _____ DOB _____ E-MAIL _____

NUMBER OF PERSONS RESIDING AT THE SERVICE ADDRESS _____ ESTIMATED GPM (Office Use Only) _____

_____ CHECK HERE IF WAIVING OPTION FOR TRAP INSTALLATION ON BUILDING SEWER [REV. 11/21/16]

If renting, provide the following Landlord information:

Landlord's Name _____

Address _____

City / State / Zip Code _____

Phone Number _____

You WILL receive a bill for sewage treatment from Johnstown Regional Sewage (533-2016).

UNSWORN VERIFICATION

The undersigned verifies that he/she is authorized to make this verification on behalf of _____; and that the statements made in the foregoing Application are true and correct to the best of his/her knowledge, information and belief. He/she understands that false statements herein are subject to the penalties of 18 Pa. C.S.A. Sec. 4904, related to unsworn falsification to authority.

Usage of the Authority's sewer service subjects the applicant to the Authority's Rules and Regulations and current rates and fees.

I, (print name) _____, have accepted rejected copies of the UYTA RULES AND REGULATIONS.

Applicant's Signature

Title

Date

UYTA Representative's Signature

UYTA
Upper Yoder Township
Authority

A PA Municipal Corporation

110 Sunray Drive, Suite 1
Johnstown, PA 15905
Phone: (814) 255-5243
Fax: (814) 255-1805

www.upperyodertownship.org

OFFICE USE ONLY	
Acct. No. _____	Book _____
CR _____	PN _____

EXISTING SERVICE

APPLICATION FOR SERVICE
COMMERCIAL-INDUSTRIAL

INSTITUTIONAL/RENTAL COMPLEX

DATE OF APPLICATION _____ SERVICE START DATE _____ OWN _____ RENT _____

CUSTOMER NAME _____

SERVICE ADDRESS _____ MAILING ADDRESS _____
(If different from service address)

CITY _____ STATE _____ ZIP _____ CITY _____ STATE _____ ZIP _____

PHONE () _____ - _____ CELL () _____ - _____ FAX () _____ - _____

FEDERAL EIN _____ LOCAL PHONE () _____ - _____ E-MAIL _____

If renting, provide the following Landlord information:

Landlord's Name _____

Address _____

City/State/Zip Code _____

Phone Number _____

NAME OF OCCUPANT OR LOCAL CONTACT PERSON _____ TITLE _____

NATURE OF BUSINESS _____ PROJECTED USAGE (GPM) _____

_____ CHECK HERE IF WAIVING OPTION FOR TRAP INSTALLATION ON BUILDING SEWER

SCHEDULE "B"

All customers will pay an equitable charge for their respective share of capacity within the Authority's sewer facilities. When applying for service, capacity fees will be based upon the prospective customer's projected water and sewer usage. Additional sewer capacity fees may be owing for this property. UYTA will contact you if applicable. The Authority MAY annually conduct a capacity analysis study. Customers found to have exceeded their original purchased or assigned usage, for any month during the twelve-month period, shall be billed additional capacity fees based upon their actual usage.

You WILL receive a bill for sewage treatment from Johnstown Regional Sewage (533-2016).

The person signing hereby attests that he/she is a duly authorized representative of applicant and has the full authority to execute this application.

UNSWORN VERIFICATION

The undersigned verifies that he/she is authorized to make this verification on behalf of _____; and that the statements made in the foregoing Application are true and correct to the best of his/her knowledge, information and belief. He/she understands that false statements herein are subject to the penalties of 18 Pa. C.S.A. Sec. 4904, related to unsworn falsification to authority.

Usage of the Authority's sewer service subjects the applicant to the Authority's Rules and Regulations and current rates and fees.

I, (print name) _____, have accepted rejected copies of the UYTA RULES AND REGULATIONS.

Applicant's Signature

Title

Date

UYTA Representative's Signature

UYTA
Upper Yoder Township
Authority

A PA Municipal Corporation

110 Sunray Drive, Suite 1
Johnstown, PA 15905
Phone: (814) 255-5243
Fax: (814) 255-1805

www.upperyodertownship.org

APPLICATION AND AGREEMENT
FOR NEW SEWER SERVICE

Date of Application: _____

The undersigned hereby makes application to the Upper Yoder Township Authority (UYTA) for sanitary sewer service for a (Residential, Commercial, or Industrial) establishment located at:

Customer Name _____

Phone No. _____

Street Address _____

Current Mailing Address _____

The undersigned does hereby covenant and agree that when a sanitary sewer connection has been provided, and after payment of all required fees for the above referenced location, the undersigned will connect to and complete the sewer lateral installation; and thereafter pay the rates established by UYTA for sewerage service; said rates being subject to change in accordance with law.

The undersigned further acknowledges that sewer EDU/capacity charges may be payable to the Johnstown Redevelopment Authority, or successor, and that monthly sewer transmission and/or treatment charges are payable to the Johnstown Redevelopment Authority, or successor, and that such rates are also subject to change in accordance with law.

The undersigned shall be responsible for using acceptable materials and construction methods as specified by the Rules and Regulations of UYTA.

Special notice is hereby given that no French drains, downspouts, storm drains, outside drains, or any other connections can be made to the applicant's or Authority's sanitary sewer lateral unless that connection carries only sanitary sewage. Basement & garage floor drains are permitted to connect to a sanitary sewer lateral, provided no surface or groundwaters flow into the same.

THE ENTIRE SEWER SYSTEM (BUILDING SEWER AND BUILDING DRAIN) MUST BE LEFT UNCOVERED, REGARDLESS OF CONDITIONS CAUSED BY WEATHER OR OTHER CIRCUMSTANCES, FOR AN INSPECTION BY THE AUTHORITY'S REPRESENTATIVE. AT A MINIMUM, THE INSTALLER MUST NOTIFY THE AUTHORITY SEVENTY-TWO (72) HOURS IN ADVANCE TO SCHEDULE SAID INSPECTION. BACKFILLING CAN ONLY BEGIN AFTER THE AUTHORITY'S INSPECTOR HAS APPROVED THE SEWER INSTALLATION.

All prospective sewer customers wishing to be connected to the UYTA sanitary sewer system shall demonstrate, to the Authority's satisfaction, that all buried sewer piping intended to be connected to UYTA facilities is in a watertight condition by performing either of two testing methods, Air or Water – and in accordance with the applicable Pennsylvania UCC/International Plumbing Code, and such Testing must be witnessed and approved by the Authority inspector who will provide written approval and acceptance, when warranted, on the Authority's Inspection Form. No customer may remain connected to the UYTA sewer lateral without securing written authorization by signature of the Authority Inspector.

RECEIPT AND PERMIT (JOHNSTOWN REDEVELOPMENT AUTHORITY, OR SUCCESSOR) IF REQUIRED

_____ Acknowledgment of payment to the Johnstown Redevelopment Authority, or successor.

\$ _____ Amount of above.

UPPER YODER TOWNSHIP AUTHORITY SEWER SERVICE CHARGES

_____ GPD (projected daily flow)*

_____ EDU (daily flow/250)

\$ _____ Connection Fee

\$ _____ Capacity Fee (\$ _____ X _____ EDU's)

\$ _____ Collection Fee (\$ _____ X _____ EDU's) UPPER YODER TOWNSHIP AUTHORITY

\$ _____ Inspection Fee

UPPER YODER TOWNSHIP AUTHORITY

\$ _____ TOTAL By _____

Authorized Signature

*NOTE: Annually the UYTA may compare actual daily flow records to that of the projected flows. Customers exceeding their projections will be billed additional charges in place at that time.

The person signing hereby attests that he/she is a duly authorized representative of applicant and has the full authority to execute this application.

UNSWORN VERIFICATION

The undersigned verifies that he/she is authorized to make this verification on behalf of _____; and that the statements made in the foregoing Application and Agreement are true and correct to the best of his/her knowledge, information and belief. He/she understands that false statements herein are subject to the penalties of 18 Pa. C.S.A. Sec. 4904, related to unsworn falsification to authority.

Usage of the Authority's sewer service subjects the applicant to the Authority's Rules and Regulations and current rates and fees.

I, (print name) _____, have accepted rejected copies of the UYTA RULES AND REGULATIONS.

Applicant's Signature

Title

Date

UYTA Representative's Signature

PLEASE RETURN TO TOWNSHIP OFFICE WITH YOUR PAYMENT

UYTA

Upper Yoder Township Authority

A PA Municipal Corporation

110 Sunray Drive, Suite 1
Johnstown, PA 15905
Phone: (814) 255-5243
Fax: (814) 255-1805

www.upperyodertownship.org

APPLICATION FOR AND CERTIFICATE OF COMPLIANCE SANITARY SEWER PRESSURE TESTING

Date _____

1. Property Owner Name: _____

Mailing Address: _____

Telephone # (home) Fax# or Mobile# Email Address

2. Service Address (if different): _____

3. Current use of Building: (Circle One) Single Family Residential Multi-Family Residential Commercial Industrial
Institutional Public Blended Use Other

4. Rental Property: (Circle One) YES NO If Yes, Number of Dwelling Units _____

5. Reason for Test (Circle One) Sewer Replaced New Connection Property Transfer Repair/Alteration
Property Financing Notice to Comply with Rules

6. Building Drain and Building Sewer (lateral) :
(Circle which apply) Building Drain Interior of Structure Building Sewer Exterior of Structure
Other (Explain) _____ Demolition

AUTHORITY REPRESENTATIVE CERTIFICATION

Authority Representative hereby CERTIFIES that he/she is not aware of any unlawful connections or any other uncorrected defects in the Building Drain and Building Sewer (lateral) installed at the above referenced service address.

Statements made herein are true and correct to the best of my knowledge, information and belief. I further acknowledge and understand that statements herein are made subject to the penalties of 18 Pa. C.S.A. Section 4904, relating to unsworn falsifications to authorities.

I have witnessed testing on the property listed above on _____, 20____

Pressure Testing (IPC § 312) of Building Drain and Building Sewer (lateral) (result): PASS FAIL

All identified problems have been corrected as of _____, 20____

Building Drain and Building Sewer (lateral) was installed by: Contractor Homeowner

Signature of Authority Representative: _____ Date: _____

Printed Name of Authority Representative: _____

Building Drain and Building Sewer (Lateral) Connection Checklist and Testing Data Sheet

(To be completed by Authority Representative)

SKETCH OF BUILDING SEWER TO MAIN

(Triangulate to Viewport and Other Critical Features)

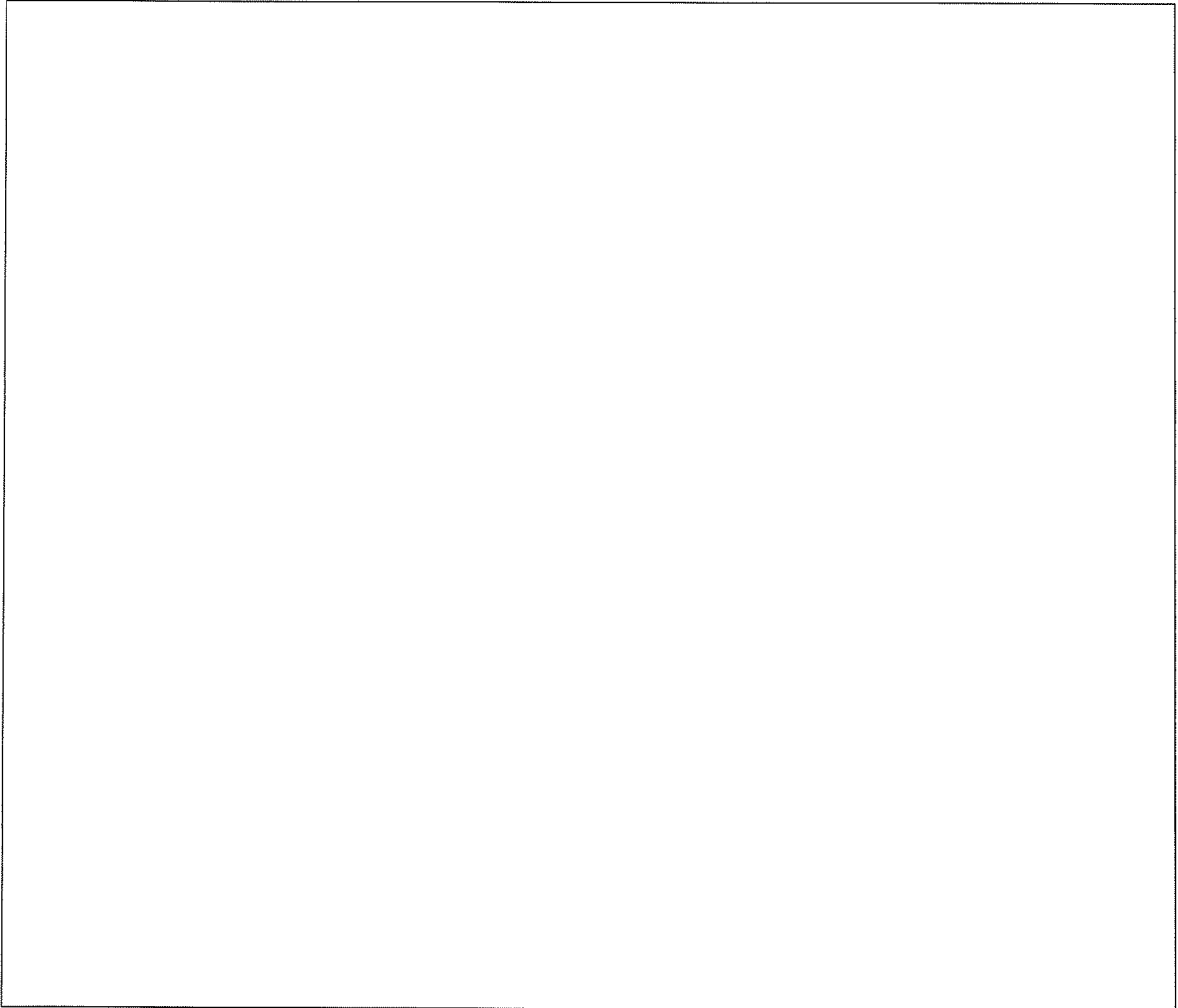

Depth of Building Sewer at Building _____ (ft-inches)

Depth of Building Sewer (Lateral) at Viewport/Main _____ (ft-inches)

Sewer Pipe Material _____

Sewer Pipe Diameter _____ (inches)

Pipe Bedding Type _____

Viewport Cover _____

Intermediate Clean-outs _____

Trap _____

Is property within the 100-year floodplain?

YES NO UNKNOWN

Basement service provided?

YES NO

SCHEDULE "D"

PAGE 4 of 7

A) AIR PRESSURE TEST (BUILDING SEWER MAIN VIEWPORT TO FOUNDATION WALL CLEANOUT):

SYSTEM INTERGRITY TEST #1 Date of Test _____ Pressure at Test Ball: _____
Time On: _____ Time Off: _____ Release Air (Duration): _____

SYSTEM INTERGRITY TEST #2 Date of Test _____ Pressure at Test Ball: _____
Time On: _____ Time Off: _____ Release Air (Duration): _____

B) AIR PRESSURE TEST BUILDING DRAIN (FOUNDATION WALL CLEANOUT TO BUILDING DRAIN-INSIDE PIPING):

SYSTEM INTERGRITY TEST #1 Date of Test _____ Pressure at Test Ball: _____
Time On: _____ Time Off: _____ Release Air (Duration): _____

SYSTEM INTERGRITY TEST #2 Date of Test _____ Pressure at Test Ball: _____
Time On: _____ Time Off: _____ Release Air (Duration): _____

A) WATER PRESSURE TEST (BUILDING SEWER MAIN VIEWPORT TO FOUNDATION WALL CLEANOUT):

SYSTEM INTERGRITY TEST #1 Date of Test _____ Water Height at Test Time: _____
Time On: _____ Time Off: _____ Water Height After 15 min. _____

SYSTEM INTERGRITY TEST #2 Date of Test _____ Water Height at Test Time: _____
Time On: _____ Time Off: _____ Water Height After 15 min. _____

B) WATER PRESSURE TEST BUILDING DRAIN (FOUNDATION WALL CLEANOUT TO BUILDING DRAIN-INSIDE PIPING):

SYSTEM INTERGRITY TEST #1 Date of Test _____ Water Height at Test Time: _____
Time On: _____ Time Off: _____ Water Height After 15 min. _____

SYSTEM INTERGRITY TEST #2 Date of Test _____ Water Height at Test Time: _____
Time On: _____ Time Off: _____ Water Height After 15 min. _____

EXPOSED EXTERIOR VISUAL PIPING INSPECTION _____

Downspouts to Daylight: YES NO

Comments _____

EXPOSED INTERIOR VISUAL PIPING INSPECTION

Interior Clean-out or Test Point: YES NO

Comments _____

FOUNDATION DRAINAGE

Sump Pump Present: YES NO UNKNOWN

Gravity Foundation Drains Present: YES NO UNKNOWN

Discharge Point (Describe Location): _____

Comment and Contact Sheet

Property Owner: _____

Service Address: _____

Phone Number: _____

COMMENTS: _____

APPROVED AND ISSUED ON _____
Date

UPPER YODER TOWNSHIP AUTHORITY

APPLICATION DENIED ON _____
Date

Signature/Title

THIS CERTIFICATE OF COMPLIANCE IS VALID FOR A PERIOD OF FIFTEEN (15) YEARS FROM THE DATE OF APPROVAL, PROVIDED THAT NO TRANSFER, ASSIGNMENT OR FINANCING HAS OCCURRED, OR WHETHER THERE ARE ANY ALTERATIONS, REPAIRS OR REPLACEMENTS PERFORMED ON THE BUILDING DRAIN OR BUILDING SEWER, AND NO EXCESSIVE FLOWS FROM THE SERVICED PROPERTY ARE SUBSEQUENTLY OBSERVED BY THE AUTHORITY REPRESENTATIVES WHICH WOULD OTHERWISE DEMONSTRATE INFLOW AND INFILTRATION VIOLATIONS.

UYTA

Upper Yoder Township Authority

A PA Municipal Corporation

110 Sunray Drive, Suite 1
Johnstown, PA 15905
Phone: (814) 255-5243
Fax: (814) 255-1805

www.upperyodertownship.org

SPECIFICATIONS FOR BUILDING SEWER INSTALLATION

MATERIALS:

All Building Sewer pipe and fittings must meet or exceed the following specifications:

- PVC (plastic) SDR-35, ASTM 3034, SCH. 40 (rubber-joint)

- PVC (plastic) C-900, SDR-21 (pressure sewer)

- DIP (ductile iron pipe) CL50, CL-51 Double Cement Line (ANSI A.21.51, A.21.10)

All Building Drain pipe and fittings must meet State-wide Building Codes.

Customers may renew the Building Sewer or Building Drain pipe by using an approved trenchless method including pipe bursting and pipe lining. All trenchless methods must be approved in advance by the Authority's Engineer. **The Engineer's decision is final with regard to approved trenchless methods.**

MANHOLES:

- Manholes must be constructed of pre-cast concrete in accordance with ASTM spec C478 and have a waterproof bituminous coating applied to the outside surface.

- All joints between the pre-cast sections shall be sealed with a waterproof gasket (Conseal).

- Manholes shall have a minimum inside diameter of 4' and an opening for a 30" frame and cover.

- All inlet and outlet pipes shall be cut off neatly and all gaps filled in with non-shrink grout.

- Manholes shall have co-polymer polypropylene steps reinforced with ½" grade 60 steel equally spaced at 12" intervals.

- Manholes bases shall have either an integral rubber gasket cast into the pipe opening of the pre-cast base at the time of manufacture, or be the compression type that fits in the cast or cored hole of the manhole (stainless steel mechanical parts only). The rubber gasket shall be manufactured in accordance with rubber joint specifications ASTM C-923. Gaskets shall be manufactured by A-LOK products, Press-Seal Gasket Corp., or approved equal.

FRAMES AND COVERS:

- Frames and covers shall be made of cast iron and shall be 30" in diameter. Covers shall be solid and be self-sealed in areas of surface water flow. Lettering "Sanitary Sewer" with UYTA shall be cast on the cover for identification.
- Frames shall be fastened and sealed to the manhole by using (4) ¾" anchor bolts and a waterproof gasket.
- Pre-cast concrete and rubber/fiber grade adjustment rings of various thicknesses and tapers shall be used where necessary to adjust the height of the manhole to the finished surface elevations. The grade adjustment rings shall have the same inside diameter as the top opening of the upper manhole section. The grade adjustment rings shall be sealed between the manhole and the adjustment ring and also between each adjustment ring and the casting with a waterproof gasket. Bricks for height adjustments are not permitted to be used.

INSTALLATION:

- The customer is responsible for and shall pay the costs for the proper installation, inspection, and maintenance of the lateral from the sewer main to the structure.
- No pipe smaller than 4" in diameter is permitted for the Building Sewer.
- No bend greater than 45 degrees horizontally may be used on the Building Sewer.
- No rubber connectors (Ferncos) are permitted for under slab or underground installation. Except for rubber connectors that are specially designed for this use, or when transitioning into a public lateral of different material.
- Eccentric reducers with integral gaskets shall be used to adapt pipe of like materials differing in size. (Example—6" SDR-35 to 4" SDR-35).
- Each Building Sewer must have an approved trap either just outside or inside the building wall. The trap must be of a type that will also serve as a cleanout. May be waived by Board at request of Customer/Occupant—at Customer/Occupant's risk.
- No storm/ground water is permitted to drain into the Sanitary Sewer System.
- All piping must be buried to a depth to prevent freezing. Recommended minimum is 3 feet.
- All pipes shall be installed at a minimum grade of ¼" per foot.
- All **Building Sewers** must be properly bedded on 4 to 6 inches of tamped gravel [2B or 2A (NO SLAG PERMITTED!)] and upon inspection and approval by the Authority Inspector, backfilled with a minimum of 12 inches of tamped gravel above the Building Sewer pipe. The remainder of the trench must be backfilled with select suitable material free of rocks larger than 4 inches in any dimension, broken concrete, roots, brush, other organic material, trash, frozen materials, or any objectionable materials. The select material must be granular and pervious in nature.

-A Viewport (inspection tee) shall be installed on the Building Sewer adjacent to the property or right of way line. All viewports shall be constructed with a 6 inch straight tee, 6 inch riser pipe and topped with a 6 inch watertight threaded plug with either a 1 ½" or a 2" inverted nut. There shall be three (3), one-half inch (1/2") (minimum) diameter metal rods, 12 inches long, taped to the top of the riser pipe at the height of the purposed finished grade. It shall be the responsibility of the property Occupant to install and maintain the viewport so that the plug remains operational and is plainly visible. The plug may not be buried, covered, or otherwise obstructed from immediate access. If the plug is not readily accessible, the Authority will give written notice to the Customer giving them 30 days to locate and make the plug operational and visible. If the Customer fails to do so, then the Authority may take any means necessary to locate, excavate, expose, raise, or otherwise make the said plug accessible and operational, and also charge the Customer for all such work.

-Viewports located within the pavement or in areas of vehicular traffic shall be protected by a cast iron frame and cover.

-A cleanout shall be installed on the Building Sewer within five (5) feet outside of the wall or on the Building Drain at the point of departure.

-Lineal distance between cleanouts shall not exceed one hundred fifty (150) feet.

-Properly sized grease and/or oil separation devices shall be required to be installed on systems serving facilities that generate grease, oils, and fats. All such facilities must be properly inspected and cleaned by the Customer on an as-needed basis as determined by Customer use.

-Buildings discharging industrial waste in the public Sanitary Sewer System must install a suitable manhole on the Building Sewer near the connecting point of the Authority's sewer main to facilitate observation, sampling, and measurement of the industrial waste. Said manhole shall be accessible, safely located, and shall be constructed in accordance with the Authority's regulations.

INSPECTION AND TESTING:

-Prior to inspection and testing, prospective Customers shall provide a plumbing diagram (on Authority's form) showing the piping layout of all buried sewer piping, including such piping buried below basement floor level. The plumbing diagram must note the pipe size, material, and the length of pipe between fittings.

-All piping installed underground, Building Sewer and Building Drains, must be inspected, tested, and approved by an Authority Inspector for compliance with the installation standards of the Authority.

-All piping is also subject to inspection by a State Wide Codes Enforcement Officer. (Contact Upper Yoder Township and inquire as to their inspection requirements.)

-Requests for inspection must be made at a minimum of seventy-two (72) hours in advance of the requested time. At the time of or prior to such requests the applicant must provide the aforementioned completed plumbing diagram to the Authority.

-Acceptable testing methods include:

-Testing by water—All buried piping shall be filled with water to a point no less than 10 feet above the highest point of plumbing that is buried or under slab. The water level must be maintained for 15 minutes without any noticeable loss of water.

-Testing by air—All buried piping shall be pressurized with air, to a minimum of 5 pounds per square inch (psi) and held with no noticeable pressure loss for 15 minutes.

-Further details of such acceptable testing can be found in the International Plumbing Code, section 312. These details may be amended from time to time.

-All work, equipment, and materials necessary to provide for and perform such testing shall be the responsibility of the Customer. The Authority Inspector shall only witness such testing and make the determination as to the correct testing procedures and the results of such testing, pass or failure. The Customer shall provide clean and safe access to the location where the testing observation is conducted. (To view the top of the 10 feet tall water column or to view the air pressure gauge.)

-The Authority Inspector shall make the sole determination as to when the actual testing commences, and thereafter expires after the 15-minute duration. Upon successful completion of the testing, the inspector shall signify their approval by affixing their signature and dating the completed sewer inspection form.

-In the event that the testing fails to meet the stated requirements, the inspector will sign and note the time and date of such failed testing on the sewer inspection form. All subsequent re-tests shall follow the same seventy-two (72) hour notice requirements, but must also be accompanied by prepayment of the \$75.00 inspection/witnessing charge. (NOTE: It is the intent of this Regulation that the Authority Inspector is scheduled only to witness a passing pressure test.)

-All manholes must be vacuum tested for water tightness. Testing must be conducted in the presence of an Authority representative. [The same seventy-two (72) hour notice applies.]

-Inlets and outlets shall be securely plugged.

-Vacuum shall be applied to a pressure 10" hg.

-The time for the vacuum to drop from 10"hg to 9"hg shall not be less than the time set forth below for the depth of the manhole.

<u>MANHOLE DEPTH</u>	<u>SECONDS</u>
8 FEET	14
10 FEET	17
12 FEET	21
14 FEET	25
16 FEET	28
18 FEET	32

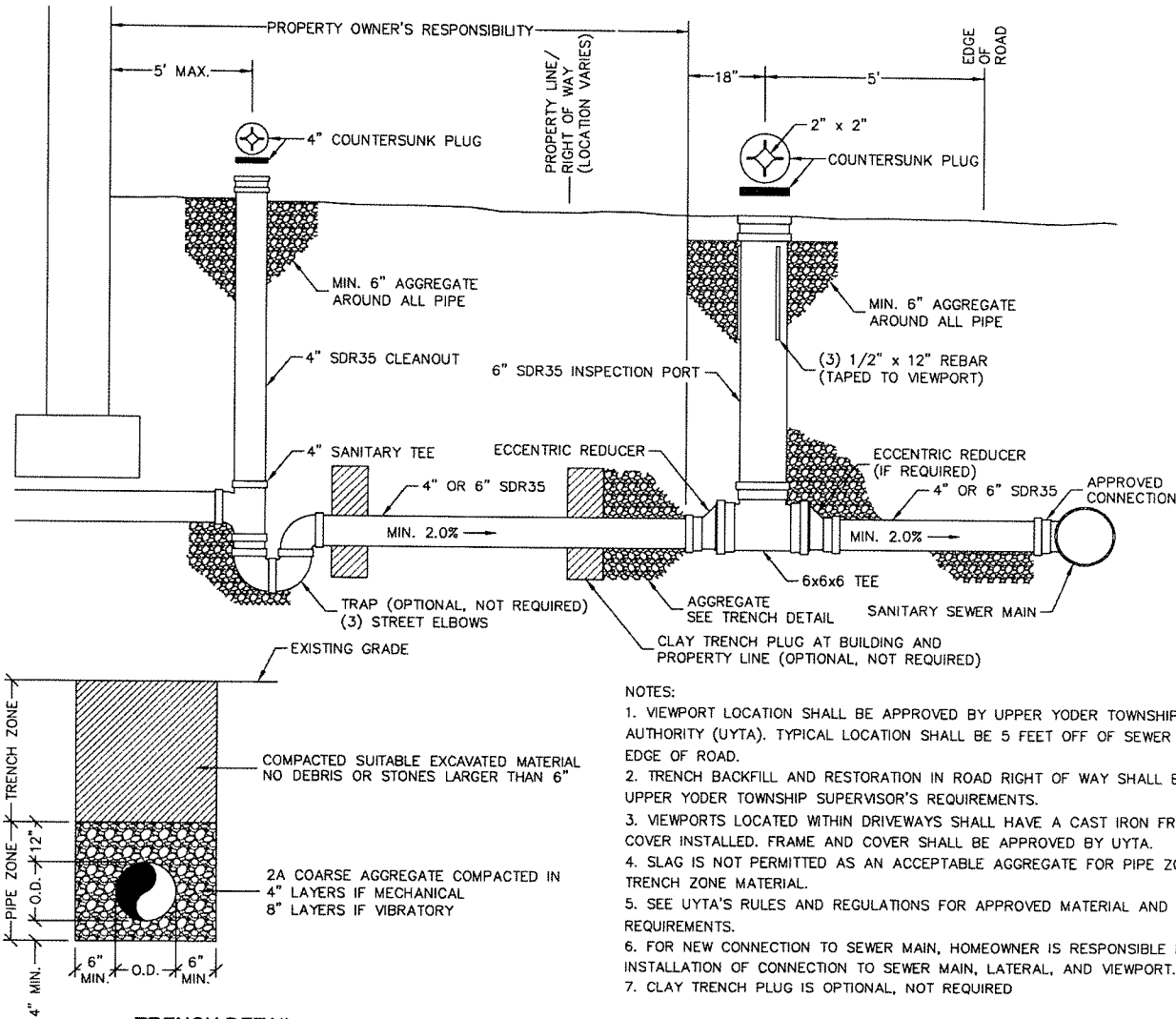

TRENCH DETAIL
NOT TO SCALE

BUILDING SEWER DIAGRAM
NOT TO SCALE

- NOTES:
- VIEWPORT LOCATION SHALL BE APPROVED BY UPPER YODER TOWNSHIP AUTHORITY (UYTA). TYPICAL LOCATION SHALL BE 5 FEET OFF OF SEWER MAIN OR EDGE OF ROAD.
 - TRENCH BACKFILL AND RESTORATION IN ROAD RIGHT OF WAY SHALL BE AS PER UPPER YODER TOWNSHIP SUPERVISOR'S REQUIREMENTS.
 - VIEWPORTS LOCATED WITHIN DRIVEWAYS SHALL HAVE A CAST IRON FRAME AND COVER INSTALLED. FRAME AND COVER SHALL BE APPROVED BY UYTA.
 - SLAG IS NOT PERMITTED AS AN ACCEPTABLE AGGREGATE FOR PIPE ZONE OR TRENCH ZONE MATERIAL.
 - SEE UYTA'S RULES AND REGULATIONS FOR APPROVED MATERIAL AND TESTING REQUIREMENTS.
 - FOR NEW CONNECTION TO SEWER MAIN, HOMEOWNER IS RESPONSIBLE FOR INSTALLATION OF CONNECTION TO SEWER MAIN, LATERAL, AND VIEWPORT.
 - CLAY TRENCH PLUG IS OPTIONAL, NOT REQUIRED

UYTA
Upper Yoder Township
Authority

A PA Municipal Corporation

110 Sunray Drive, Suite 1
Johnstown, PA 15905
Phone: (814) 255-5243
Fax: (814) 255-1805

www.upperyodertownship.org

TIME EXTENSION AGREEMENT
For
SANITARY SEWER COMPLIANCE
Residential Property

The subject property is located at: _____ Johnstown, PA 15905

(Street Address)

Upper Yoder Township, Cambria County, PA

(a): The Undersigned has a sale or financing pending, but is unable to bring the Property into compliance for the following reason(s) and is subject to the Rules and Regulations of Upper Yoder Township Authority (a copy of which is attached hereto) which require a passing pressure test, as evidenced by an Authority Certificate Of Compliance prior to the closing of any transfer in interest or refinancing of any Property serviced within the Authority's sewer system:

(b): The Undersigned acknowledges receipt of a thirty (30) day notice of the five (5) months required to bring the subject Property serviced by the Authority into passing pressure testing compliance, in conjunction with the Authority's Sewer System Rehabilitation Project, but is unable to bring the Property into compliance within the time required for the following reason(s):

The Undersigned shall perform a passing pressure test as supervised by the Authority's representative from the viewport to a clean-out no more than five (5) feet from the outside wall of the property, no later than sixty (60) days from the Authority's grant of extension of this Agreement. If no such clean-out or viewport exists on the Property, it is the Undersigned's responsibility to have the clean-out or viewport installed. The Undersigned further understands and agrees that all fees, labor and materials necessary for compliance shall be at the sole cost and expense of the Undersigned. The Undersigned also guarantees to comply with pressure testing from the clean-out to the Building Drain within twelve (12) months of the Authority's grant to extend compliance time.

The Undersigned, being the Owner/Transferor, Buyer/Transferee and/or Mortgagor, hereby acknowledges the validity of Upper Yoder Township Authority's Rules and Regulations and intends to comply fully with the requirements thereof in a timely manner, in consideration of an Extension of the deadline for said Compliance. The Undersigned further understands and acknowledges that as a precondition for an extension, the Undersigned understands that in the case where complying with said Regulation would cause an undue hardship, the Authority may grant, in its sole discretion on a case-by-case basis, a limited extension of time within which to comply. The Undersigned must comply with the terms of this Extension Agreement, provide proof of a bona-fide contract which guarantees that the contractor or the Undersigned shall perform the work required to bring the property into compliance and shall submit proof that one hundred ten percent (110%) of the funds necessary to accomplish the same have been escrowed or are otherwise guaranteed to be available and, if applicable, provide proof of a real estate sales agreement which contains provisions identifying the parties' obligations concerning Sanitary Sewer Compliance.

The Undersigned shall perform a passing pressure test as supervised by a representative of the Authority no later than (Date) ____/____/____

Owner/ Transferor:

Buyer / Transferee/Mortgagor:

(Print) (Print)

(Signature) (Signature)

____/____/____
(Date) (Date)

(Phone)

(Print) (Print)

(Signature) (Signature)

____/____/____
(Date) (Date)

(Phone)

Upper Yoder Township Authority:

Authorizing Agent: _____
(Print) Name and Title

(Signature)

____/____/____
(Date)

****Please Note:** The Upper Yoder Township Authority Rules and Regulations provide that water service may be terminated if a passing sewer pressure test is not completed by Extension date and that non-compliance may result in Summary prosecution and the imposition of non-compliance fees.

UYTA
Upper Yoder Township
Authority

A PA Municipal Corporation

110 Sunray Drive, Suite 1
Johnstown, PA 15905
Phone: (814) 255-5243
Fax: (814) 255-1805

www.upperyodertownship.org

TIME EXTENSION AGREEMENT

For

SANITARY SEWER COMPLIANCE

Commercial Property

The subject property is located at: _____ . Johnstown, PA 15905
(Street Address)

Upper Yoder Township, Cambria County, PA

(a): The Undersigned has a sale or financing pending, but is unable to bring the Property into compliance for the following reason(s) and is subject to the Rules and Regulations of Upper Yoder Township Authority (a copy of which is attached hereto) which require a passing pressure test, as evidenced by an Authority Certificate Of Compliance prior to the closing of any transfer in interest or refinancing of any Property serviced within the Authority's sewer system:

(b): The Undersigned acknowledges receipt of a thirty (30) day notice of the five (5) months required to bring the subject Property serviced by the Authority into passing pressure testing, in conjunction with the Authority's Sewer System Rehabilitation Project, but is unable to bring the Property into compliance within the time required for the following reason(s):

The Undersigned shall perform a passing pressure test as supervised by the Authority's representative, from the viewport to a clean-out no more than five (5) feet from the outside wall of the property, no later than sixty (60) days from the Authority's grant of extension of this Agreement. If no such clean-out or viewport exists on the property, it is the Undersigned's responsibility to have the clean-out or viewport installed. The Undersigned further understands and agrees that all fees, labor and materials necessary for compliance shall be at the sole cost and expense of the Undersigned. The Undersigned also guarantees to comply with pressure testing from the clean-out to the Building Drain within twelve (12) months of the Authority's grant to extend compliance time.

The Undersigned, being the Owner/Transferor, Buyer/Transferee and/or Mortgagor, hereby acknowledges the validity of Upper Yoder Township Authority's Rules and Regulations and intends to comply fully with the requirements thereof in a timely manner, in consideration of an Extension of the deadline for said Compliance. The Undersigned further understands and acknowledges that as a precondition for an extension, the Undersigned understands that in the case where complying with said Regulation would cause an undue hardship, the Authority may grant, in its sole discretion on a case-by-case basis, a limited extension of time within which to comply. The Undersigned must comply with the terms of this Extension Agreement, provide proof of a bona-fide contract which guarantees that the contractor or the Undersigned shall perform the work required to bring the property into compliance and shall submit proof that one hundred ten percent (110%) of the funds necessary to accomplish the same have been escrowed or are otherwise guaranteed to be available and, if applicable, provide proof of a real estate sales agreement which contains provisions identifying the parties' obligations concerning Sanitary Sewer Compliance.

The Undersigned shall perform a passing pressure test no later than (Date) ____/____/____

Owner/ Transferor:

Buyer / Transferee/Mortgagor:

_____	_____	_____	_____
(Print)	(Print)	(Print)	(Print)
_____	_____	_____	_____
(Signature)	(Signature)	(Signature)	(Signature)
____/____/____	____/____/____	____/____/____	____/____/____
(Date)	(Date)	(Date)	(Date)
_____	_____	_____	_____
	(Phone)		(Phone)

Upper Yoder Township Authority:

Authorizing Agent: _____
(Print) **Name and Title**

(Signature)

____/____/____
(Date)

****Please Note:** The Upper Yoder Township Authority Rules and Regulations provide that water service may be terminated if a passing sewer pressure test is not completed by the Extension date and that non-compliance may result in Summary prosecution and the imposition of non-compliance fees.

Upper Yoder Township Authority

A PA Municipal Corporation

110 Sunray Drive, Suite 1
Johnstown, PA 15905
Phone: (814) 255-5243
Fax: (814) 255-1805

www.upperyodertownship.org

GENERAL GUIDE FOR CERTIFICATION OF PRESSURE TESTING BUILDING SEWERS – REFER TO RULES

Procedures for lateral testing certification (Building Sewer)

- In order to comply with the Upper Yoder Township Authority Rules and Regulations, buildings that have public sewer service provided by Upper Yoder Township Authority must pass a pressure test of all underground piping and must pass a visual inspection of interior sanitary sewage piping. The pressure test must be supervised by a designated Authority Representative. Refer to the Authority Rules and Regulations for specific compliance requirements.
- When the pressure testing and visual inspection is approved, the Authority will issue a Certificate Of Compliance, Sanitary Sewer Pressure Testing.
- The Certificate will be valid for a period of 15 years, unless required more frequently if the Building Sewer as previously tested is repaired, replaced, or altered.
- Any sale, transfer or financing of property will require a Certificate of Compliance, Sanitary Sewer Pressure Testing.
- The entirety of the property owners' Building Sewer, including underground and under-slab piping, must be tested including the Building Drain and Building Sewer to the viewport.
- The owner shall pay for all inspection, testing fees, installations, repairs or replacement including labor, materials and equipment necessary, including viewports if none exist, in order to bring the Building Sewer into compliance with Upper Yoder Township Authority Rules and Regulations.
- Requests for inspection and supervision of the testing must be made a minimum of 72 hours in advance of the requested time. Requests can be scheduled between 9:00 am and 4:00 pm by calling the Authority's Project Manager at (814) 255-5243, Ext. 228 or 226. Weekends and Holidays are excluded.
- The Authority's inspector will allocate 45 minutes on site for the inspection whether the test passes or fails. The property owner will have to reschedule and pay the required fees prior to each subsequent inspection.
- The Authority imposes a \$75 fee for each inspection or re-inspection. The fee shall be made payable to Upper Yoder Township Authority and paid at the time of application for the inspection. An additional \$75 shall be paid in advance for every re-test inspection.

- **Acceptable test method:**
 - Air Pressure Test- sanitary sewer piping must pass an air test of 5 psi for 15 minutes (no pressure drop)
 - Water Pressure Test – all buried piping shall be filled with water to a point no less than 10 feet above the highest point of plumbing that is buried. Water level must be maintained for 15 minutes if noticeable loss of water.
- See attached Drawing, Page 5 of 5, for sample of testing requirements.
- Property owners shall complete the property owner information and sign the Application For and Certificate Of Compliance: Sanitary Sewer Pressure Testing, prior to or at the time of inspection. When appropriate, the property owner’s contractor may also be required to complete the Application.
- Property owners refuse to install a trap, they shall sign trap waivers prior to or at the time of inspection.

Terminology

- Viewport - the transition point from sewer lateral (Authority owned system) to the privately owned Building Sewer (lateral).Upon installation, it is the property of the Authority – see Rules.
- Cleanout – property owner shall install a cleanout to Authority specification for routine maintenance of the Building Sewer line. Cleanouts shall be adequately capped at all times – see Rules.
- Building Drain – any sanitary sewer piping within the foot print of the structure –see Rules.
- Building Sewer - any sanitary sewer piping from foundation wall to viewport see Rules.

If repairs are required after the 1st test, the repairs shall follow the specifications below and the building sewer (lateral piping) must be inspected BEFORE backfilling.

- All new Building Sewer piping shall be left uncovered for inspection by the Authority Representative certifying to the pressure test.
- Roof, surface, foundation, or underground/storm water drainage is **NOT** permitted.
- Floor drains are permitted but not required, unless the Authority Representative determines the floor drains to be an illegal connection such as allowing water to enter the Building Sewer from non-domestic, extraneous sources.
- All piping shall be installed in conformity with the manufacturer’s recommendations.
- **All pipes shall be properly bedded on a 4” to 6” layer of compacted stone (2A or 2B limestone or sandstone)** and, upon inspection and approval by the Authority Representative, backfilled with 12” of compacted stone above the crown of pipe with the remainder of the trench backfilled with select suitable material. **NO SLAG is PERMITTED for pipe bedding.**
- All Building Sewer (lateral) pipes shall be installed with a minimum slope of ¼” per foot.
- All pipes shall be laid with full and even bearing with no block support.
- Pipe diameter from stack to viewport shall be maintained without pipe reduction.
- When transitions between SDR 35 and SCH 40 are needed, solid sleeve couplings shall be used.
- Where connections to existing pipes are required and a solid sleeve coupling is **NOT** manufactured, a **reinforced coupling** is required.
- Eccentric Reducers are required to maintain constant flow line.
- See attached Drawing, Page 4 of 5, for repair details.

Building Drain

- No pipe shall be smaller than 2" diameter for any Building Drain.
- All Building Drain pipes and fittings shall meet or exceed (SDR 35 ASTM D3034 or PVC Schedule 40 ASTM D1785) or (CL50, CL51 double cement lined ANSI A.21.51, A.21.10 for DIP ductile iron pipe).

Building Sewer

- All Building Sewer pipe shall be a minimum of 36 inches deep from the crown of the pipe.
- No pipe shall be smaller than 4" diameter for Building Sewers.
- No bend greater than 45 degrees on the horizontal shall be installed on the Building Sewer.
- All Building Sewer pipe and fittings must meet or exceed (SDR 35 ASTM D3034) or (CL50, CL51 double cement lined ANSI A.21.51, A.21.10 for DIP ductile iron pipe).
- Solvent weld joints will **NOT** be permitted on the Building Sewer.
- A vented trap should be installed at approximately five feet from the building. Property owner shall sign a waiver if a vented trap is not installed. Solvent weld joints are **NOT** be permitted to construct the trap.
- Cleanouts shall be provided at 90 feet intervals and at every 45-degree, horizontal bend.
- A backflow prevention valve is permitted, but not required. The location of the backflow prevention valve shall be as close to the viewport as possible. If a backflow prevention valve is to be installed, please contact an Authority Representative prior to installation for more specifications and information.
- The Authority recommends but does not require the installation of clay trench plugs on the Building Sewer.

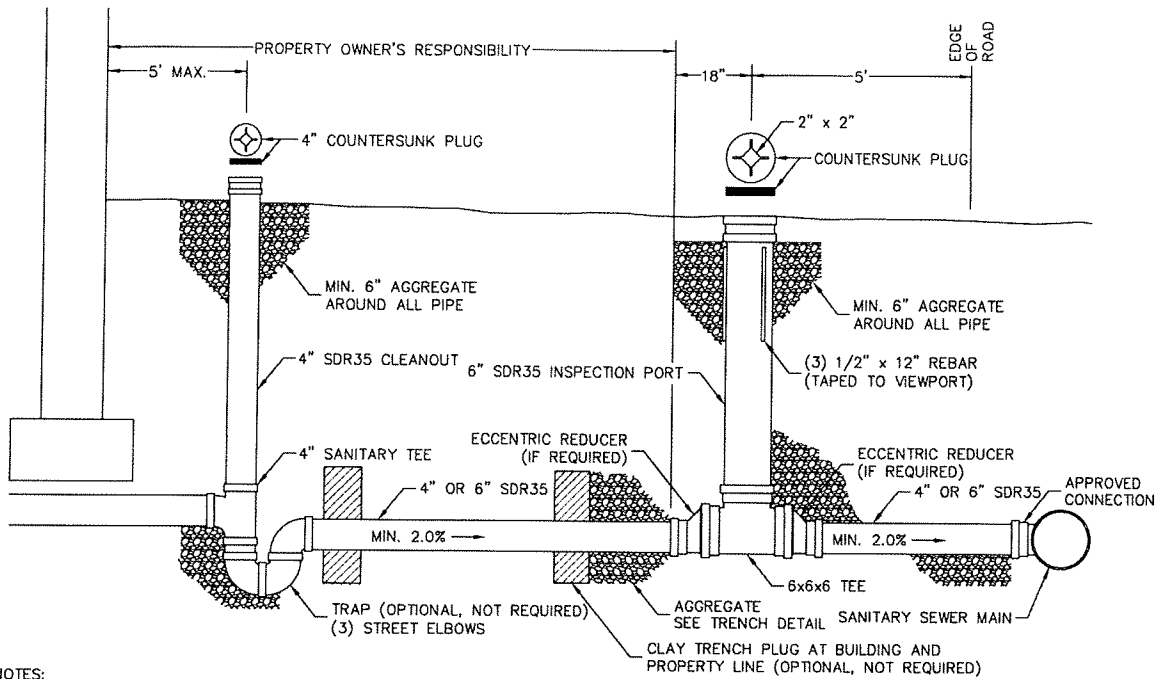

NOTES:

1. WHEN SEWER MAIN IS ADJACENT TO ROAD OR IN EASEMENT INSPECTION PORT SHALL BE 5 FEET OFF OF SEWER MAIN.
2. CLEANOUT MAY BE LOCATED INSIDE THE FOUNDATION WALL.
3. FOR NEW CONNECTION TO SEWER MAIN, HOMEOWNER IS RESPONSIBLE FOR INSTALLATION OF CONNECTION TO SEWER MAIN, LATERAL, AND VIEWPORT.

TYPICAL BUILDING SEWER INSTALLATION

NOT TO SCALE

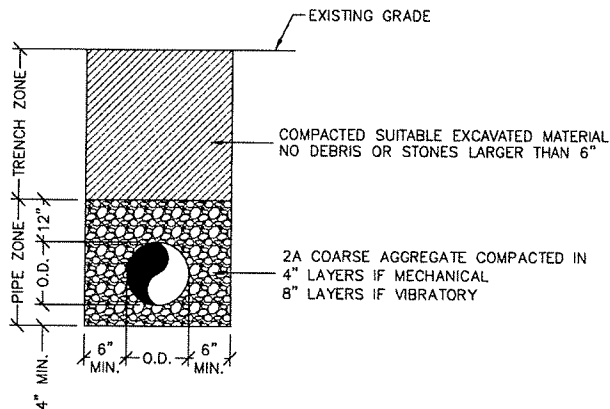

NOTE:
SLAG IS NOT PERMITTED WITHIN THE PIPE ZONE OR THE TRENCH ZONE.

TRENCH DETAIL

NOT TO SCALE

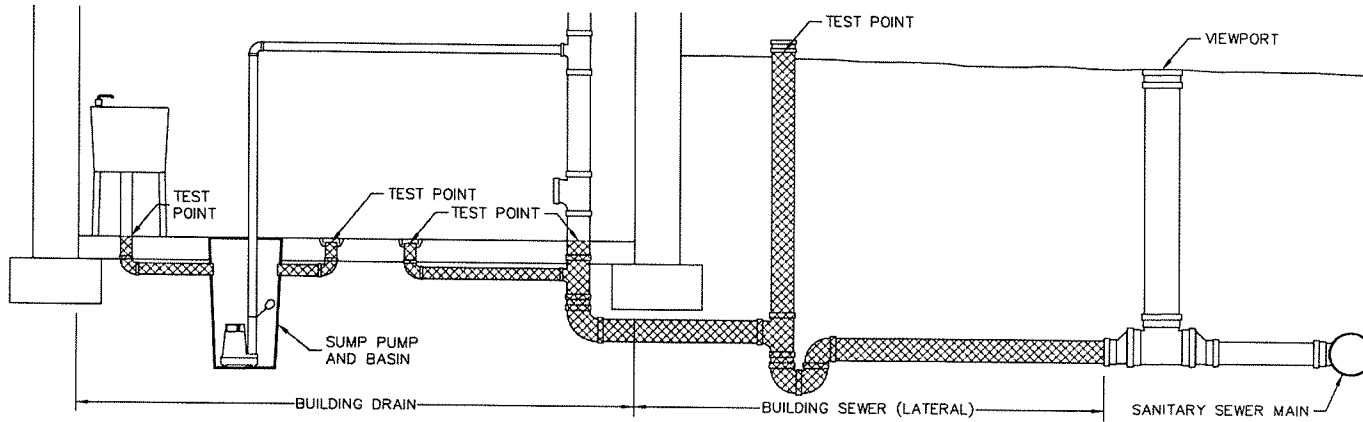

NOTES:

1. IF VIEWPORT IS INSTALLED, MODIFIED, OR DISTURBED BY HOMEOWNER THEN VIEWPORT MUST BE INCLUDED IN PRESSURE TEST.
2. SUMP PUMP BASIN MUST BE A PRE-MANUFACTURED BASIN WITH APPROVED CONNECTIONS OR A VACUUM TEST IS REQUIRED.

 PIPES THAT REQUIRE PRESSURE TEST

TESTING REQUIREMENTS FOR BUILDING DRAIN AND BUILDING SEWER

NOT TO SCALE

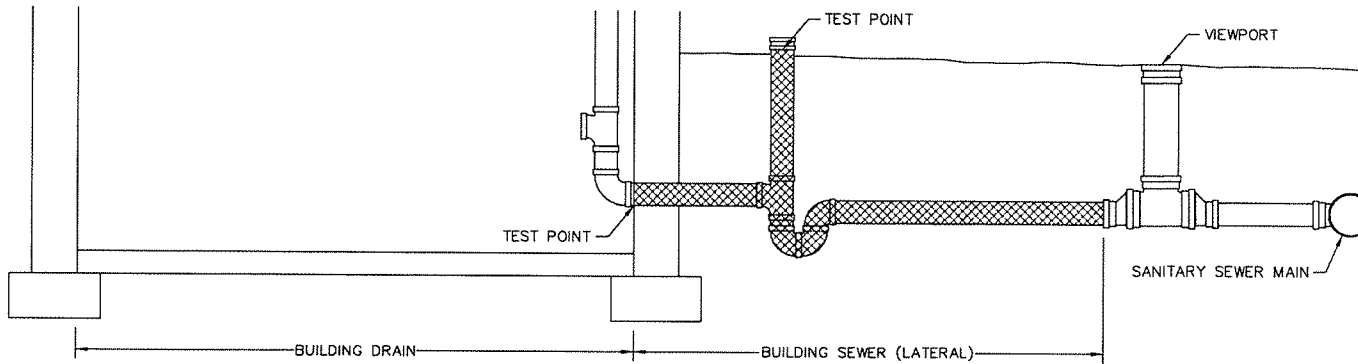

NOTE:

- IF VIEWPORT IS INSTALLED, MODIFIED, OR DISTURBED BY HOMEOWNER THEN VIEWPORT MUST BE INCLUDED IN PRESSURE TEST.

 PIPES THAT REQUIRE PRESSURE TEST

TESTING REQUIREMENTS FOR BUILDING SEWER

NOT TO SCALE

UYTA

Upper Yoder Township Authority

A PA Municipal Corporation

110 Sunray Drive, Suite 1

Johnstown, PA 15905

Phone: (814) 255-5243

Fax: (814) 255-1805

www.upperyodertownship.org

SCHEDULE I - RESERVED

UYTA

**Upper Yoder Township
Authority,**

A PA Municipal Corporation

110 Sunray Drive, Suite 1
Johnstown, PA 15905
Phone: (814) 255-5243
Fax: (814) 255-1805

www.upperyodertownship.org

"A" AGREEMENT FOR CONTRACTORS

AGREEMENT FOR EXTENSION OF A SEWER COLLECTION SYSTEM TO MAKE SEWER SERVICE AVAILABLE BY EXTENSION DESCRIBED ON EXHIBIT "A" ATTACHED HERETO AND MADE A PART HEREOF.

THIS AGREEMENT, made and concluded this _____ day of _____, 20__ by and between _____ hereinafter referred to as Applicant or Applicants,

AND

UPPER YODER TOWNSHIP AUTHORITY, hereinafter referred to as the Authority,

WITNESSETH:

FIRST: THE APPLICANT OR APPLICANTS AGREE:

- (a) That they propose the installation of a _____ L.F. of _____ sewer line extension as described on Exhibit "A" attached hereto and made a part hereof. Such extension is intended to serve Lots ___ through ___ in the _____ subdivision, Upper Yoder Township, Cambria County, PA. Said extension will be built as to plans approved by the Authority and in accordance with the Rules and Regulations and Specifications of the Authority. Applicant(s) further agree to pay the cost of the Authority appointed inspector who will observe the actual installation of said extension, along with assuming the cost of having the sewer line and appurtenances pressure tested and vacuum tested to the Authority specifications, and further, to pay the cost of having the Authority oversee said testing.

- (b) Applicant(s) will submit one (1) set of reproducible and two (2) copies of "AS-BUILT" drawings, in accordance with Authority requirements. Plans shall be prepared using a computer aided design (CAD) system of, or compatible with, AutoCad Release 14 or later version. All Specifications and Addenda shall be provided in Microsoft Word format. Plans shall be in State Plane Coordinates (SPC), NAD 1983 Pennsylvania State Plane South. Plans shall include and show at least two (2) survey control points, showing their State Plane Coordinates. The Plans shall also include at least two (2) permanent Benchmarks, with their respective coordinates, and elevations tied to USGS Datum based on the As-Built elevation of Upper Yoder Township Authority's closest facility. The accuracy must be at least sub-centimeter Survey Grade. Plans shall be provided as; 1 Mylar (18' x 24'), 8 Prints (either 24' x 36' or 30' x 42') and 1 Compact Disk (CD) in a scale no smaller than 1" = 100' HORIZONTAL and 1" = 10' VERTICAL. Said drawings to be done by a registered engineer, architect or surveyor.
- (c) Applicant(s) do hereby agree to give, grant and convey to the Authority, via a separate document, a perpetual right of way, sufficient in width to maintain, replace, repair, renew, inspect, install service connections or connect onto said extension within the lines of the street or streets, which said extension is to be placed and over and upon and under any land owned by the Applicant(s) over and upon and under which said extension is placed, and hereby release the Authority and agree to save harmless the Authority of and from all damages or claims to damages, for or on account of or about installation, maintenance, repair and replacement of said extension. If it is necessary to obtain perpetual rights of ways from others, Applicant(s) will obtain and deliver to the Authority all such rights of ways, with release or releases of damages, similar to the release hereinabove mentioned.
- (d) To provide to the Authority a statement for expenditures showing a breakdown of the total cost incurred by the Applicant(s) to have the above-mentioned line extension installed. The statement for expenditures shall be prepared by a certified public accountant, public accountant, a registered engineer or architect and shall contain a sufficient breakdown to apprise the Authority of the cost to buy labor, materials and other acceptable classifications. Said Cost Breakdown shall be provided within sixty (60) days following completion of construction on those facilities contained therein.

SECOND: IT IS MUTUALLY AGREED

- (e) That the said extension, together with necessary service connections, fittings, etc. shall be dedicated to and shall become the sole property of the Authority, free of any lien, encumbrance or charge whatsoever.
- (f) Where applicable, Applicant(s) shall pay for sewer service, and be bound by the Rules and Regulations and appropriate rate schedule of the Authority, then prevailing.
- (g) Applicant(s) agree to a one (1) year guarantee of the sewer line extension and related appurtenances from the date of construction completion. Should the sewer line extension and / or related appurtenances malfunction, fail or leak, the Authority will take the necessary measures to correct the problem and invoice the Applicant(s) for the total cost incurred.

- (h) In determining the length of, and the necessity for, any extension to a bona fide customer, the beginning point of such extension shall in all cases be at the location as determined by the Authority, and the terminal point of such extension shall be at a point perpendicular to and twenty feet (20') beyond the designated point of entry where the service line enters or is proposed to enter the last structure intended to be served, except that such terminal point shall not be located within the bounds of a driveway. In such cases the terminal point shall be extended beyond, to avoid ending within any driveway and apron / approaches. In the event the Applicant changes the location of the point of entry for the proposed service line, or the location of the proposed structure intended to be serviced, the terminal point of the sewer line extension shall be field adjusted by the Authority to a point which complies with this rule.
- (i) Applicant(s) agree that they will not connect to any service connection, tap or lateral they may have installed as part of this Line Extension without first having made application and paid the appropriate fees or charges to Upper Yoder Township Authority.
- (j) Applicant(s) acknowledge they are aware that a PaDEP moratorium exists on Upper Yoder Township Authority's sewer system and that additional taps (EDUs, i.e., Equivalent Dwelling Units) are permitted only on a limited basis annually. In order to secure a guarantee of service, for itself or for future lot purchasers within the subdivision, the Applicant must pay for taps/EDUs whenever Upper Yoder Township Authority has an available allotment. There is no guarantee that EDUs (service) will be available for purchase at such future time as Applicant may wish to build. Accordingly, the Authority recommends that the Applicant purchase, before December 31st, available EDUs each year for use in subsequent years.
- (k) This Agreement constitutes a binding contract by and between the parties hereto, their heirs, executors, administrators, successors and assigns, respectively.

IN WITNESS WHEREOF, and intending to be legally bound hereby, the parties hereto have hereunto set their hands and seals the day and year first above written.

WITNESS:

ATTEST:

UPPER YODER TOWNSHIP AUTHORITY

Secretary

By: _____
Chairman

EXHIBIT "A"

(Provide a Narrative description explaining the line extension. Additionally, provide a drawing which clearly shows the route and extent of the line extension. 8.5" x 14" or 11" x 17")

Upon inquiry, by the Applicant, as to the availability of sanitary sewer service within the Upper Yoder Township Authority system, said Applicant shall be provided a Preliminary Application form and a copy of this Packet which details the requirements which must be met prior to a formal review, by the Authority, of any applicable development proposal. The Applicant must complete and return this page (in its entirety) along with Applicant's formal submission as described herein.

Packet Received By:

___/___/___

SIGNATURE of Applicant

DATE

PART I (GENERAL) :

1. All Applicants proposing development of a Commercial or Industrial property, or a subdivision of Residential, Commercial or Industrial nature, shall make written inquiry to the Authority as to the location, size and available capacity in the Authority's existing water and/or sanitary sewer facilities. Said Authority facilities shall then be plotted, by the Applicant, on the Site Utility Plan (Site Plan) (Attachment I) to adequately show the location of such facilities in relation to the proposed development.
2. Those projects seeking confirmation that sanitary sewer service can be provided to the intended development shall submit 3 copies of a Project Narrative (Attachment II) along with 3 copies of the Site Plan, along with a completed Application and a Review Fee (See Below), as determined by the Authority, in an amount estimated to cover the costs incurred to conduct the requested project review.

Review Fees To Be Paid in Advance:

\$ 25 Application Fee.

\$ 500 Escrow for Engineer Review

The above fees allow for an Initial submittal and one (1) subsequent resubmittal of revised Plans. If a third filing is necessary, **additional fees to be paid In advance, in accordance with the Authority's Engineering rates which are in effect from time to time, will be required.**

In addition, a Plan(s) determined by the Authority to also require review by its Consulting Engineer will be required to submit **an additional** Deposit equal to the estimated cost to complete such review or resubmittal thereof. The Authority may also require additional Deposits into escrow after the initial and resubmittal of Plan(s). **The Authority shall determine the amount of the Deposit on a case-by-case basis based on the complexity and scope of the submitted project and Plan(s).** When so required, the additional Deposit shall be paid concurrent with each subsequent resubmittal.

3. The Completed Application, Project Narrative, Site Plan, Review Fee and Deposit (if required) must be submitted a minimum of 10 working days prior to the next regularly scheduled Authority meeting. (Meeting dates are 3rd Monday of each month). During said 10-day review period the Authority will complete its review and make the determination as to compliance with its Rules and Regulations. Any Proposal found to be incomplete or in conflict with the Authority's Rules and Regulations shall be rejected and the Applicant notified of such within 5 days after expiration of the review period. Any development proposal determined to be acceptable shall be recommended to the full Authority Board for approval during its next regular meeting. The Authority Board will take formal action on the recommended proposal, either approving or, for just cause, rejecting the Plans/Proposal as submitted. Said determination will subsequently be provided in writing to the Applicant within 5 working days. (Board approval of sanitary sewer service proposals does not constitute a guarantee of service. Such guarantee is extended only upon payment of the appropriate EDU fees by the Applicant/Owner.)
4. Where the Authority is requested to sign any Page, or part thereof, of a PaDEP Planning Module, or to attest by signature that a development qualifies for an exemption, said Authority signature will only be provided upon determining if sufficient capacity exists in the sanitary sewer system to accommodate the project and the receipt of the appropriate EDU fees. **Eight (8)** copies of a fully completed Planning Module or fully completed Exemption request, accompanied by the aforementioned Project Narrative and Site Plan must be submitted. No alteration, addition or deletion shall be made to such document after it is signed by the Authority.
5. In cases where extensions of existing facilities are required the Applicant shall plot and clearly denote the location of existing facilities and the location of the required extension(s) on a set of Sewer Construction Plans (Attachment III). The Authority's Rules and Regulations require extensions to begin at the nearest existing facility capable of providing the intended service and said extension(s) shall terminate at a point perpendicular to and twenty (20) feet beyond the designated point of entry where the Sewer service line enters or is proposed to enter the last structure served, or in the case of vacant lots at a point twenty (20) feet beyond the center of the permissible building area of the last lot to be served. Such stipulations also apply when extensions are required to serve a single lot or parcel.
6. Each plan drawing must include a space for an Authority signature and approval stamp.

ALL FORMAL APPLICATIONS SHALL THEREFORE BE COMPRISED OF:

(3) Copies of:

1. Returned, original, signature page.
2. Site Plan, (and Extension Construction Plans where applicable).
3. Project Narrative.
4. Specifications for Sewer installations.
5. Review Fees (Per Rate Schedule) check, and Deposit check (when required) for additional estimated review costs of contracted Consultant.

ATTACHMENT I

Site Utility Plan (Site Plan)

The Applicant shall ascertain the location of all existing utilities and plot same on the Plan. If needed, the location of the existing facilities shall be field located by inquiry to the PA One-Call System. The designer shall then plot all facilities as to their actual field location.

The Plan shall be sufficient in detail to allow any reviewer to determine the exact nature and scope of the work proposed. The Plan shall include but not be limited to:

- * Entire perimeter property boundary of the lot or parcel being developed shall be shown and described. Each individual lot or parcel within that boundary shall be individually identified.
- * Location of any and all planned buildings and structures, and future additions thereto within the lot or parcel.
- * Location and labeling of all existing and proposed utilities (including storm sewers) and associated rights-of-ways, pavement, structures, drainage courses, etc.
- * Contour lines at minimum 5' intervals.
- * Title Block with Date, with provisions for Revision's documentation.
- * Scale of 1" = 50' (Horizontal) and 1" = 10' (Vertical) or pre-approved alternative scale.
- * North arrow, with Plan oriented so that North is toward the top half of the Plan.
- * Location insert.
- * Labeling of the name and legal R/W width of all public thoroughfares (Roads, Alleys) adjoining the property.
- * Adjacent properties labeled with designation and owner. (Not necessary to plot entire adjacent property – only the common corner(s) and short line there from).
- * Labeling shall clearly show the location, depth or elevation, size and pipe material for both existing and proposed sanitary sewer facilities.
- * Locate and label all existing and proposed fixtures (bends, tees, valves, manholes, lamp holes, view ports, taps, etc.) of both existing and proposed sewer facilities, including service connections and service laterals.
- * Existing and proposed grading.

ATTACHMENT II

Project Narrative

Shall be brief, but detailed, and allow the reviewer to determine the full scope of the development proposed. Shall include, at a minimum:

- * Location, Name and Nature of the Development
- * Projected water usage (average and peak flows) of full development or any phasing thereof.
- * Size of proposed service connections.
- * Projected sewage flows (average and peak), and conversion thereof to EDU's. (NOTE: 1 SANITARY SEWER EDU EQUALS 250 GPD).
- * Development schedule.
- * Anticipated date service is needed.
- * Description of proposed line extensions required, if applicable.
- * Factors which may influence viability or scope of Project.

ATTACHMENT III

Sewer Construction Plans

All the requirements pertaining to the aforementioned Site Plan shall apply, in addition to the following:

- * Each drawing shall be individually numbered or identified.

Sewer – Plan Drawings:

- * Title Page, including Project Name/Location, Owner and Address/Phone No., Designer and Address/Phone No.
- * Scale and North shall be indicated on each sheet.
- * Each manhole, lamp hole, wye or other appurtenances shall be shown and noted to its corresponding stationing.
- * Service laterals, in all cases, shall be extended from the main line to the edge of the Road R/W or Private R/W. Stationing shall be provided for the wye branch connection and for the end of the service lateral where said end is not perpendicular to said wye branch.
- * The pipe material, diameter, length and slope shall be noted for each run of sewer main between manholes.
- * Dimension from sewer main to property line and dimension to next closest "facility" (3' to curb, 5' to edge of pavement, 3' to catch basin, etc.)
- * Each manhole shall be identified by an individual number/letter designation.
- * Show all existing and proposed surface structures (pavement, concrete, catch basins, vaults, poles, foundations, etc.)
- * Reference must be noted that installation must comply with Upper Yoder Township's s Detailed Technical Specifications, as in force at the time of construction.
- * Distance from nearest property corner to end of sewer lateral and depth at that location.
- * Standard Details, per Township Specifications, shall be included.
- * Seal of Registered Professional Engineer or Surveyor.

Sewer – Profile Drawings:

- * Each Invert and Outlet elevation shall be noted at each manhole, along with the elevation to top of manhole cover.
- * Stationing shall be provided for each manhole, lamp hole, wye or other appurtenances located on the sewer main.
- * Pipe length, diameter, material and slope shall be noted on each pipe run between manholes.
- * Locate and describe each facility which crosses, above or below, the proposed sewer main. (i.e., 12" RCP Storm Sewer, 3" PVC Gas Main, 4" PVC Conduit w/23Kv Electric, etc.)
- * Manhole designation (number/letter) from Plan shall also be noted on Profile.
- * Existing and Finished grade shown (Existing – dotted line, Finished – solid line).
- * Horizontal, and Vertical Scale noted on each sheet.
- * Seal of Registered Professional Engineer or Surveyor.

"As-Built" Plans:

- A. Private Facilities – At a minimum, Red Lined Drawings must be provided of those facilities on-site, where ownership and maintenance responsibility are retained by the property owner, although a Mylar is preferred.
- B. Public Facilities – Shall be prepared using a computer aided design (CAD) system. The CAD drawing(s) shall be prepared on or be compatible with AutoCAD Release 14 or later. All specifications and addenda shall also be included in Microsoft Word Format. The Plan shall be in State Plane Coordinates and the elevations shall be in USGS Datum. The Plan shall include at least two (2) survey control points with State Plane Coordinate Values and two (2) Bench Marks with elevations based on USGS Datum. The accuracy must be at least survey grade, sub centimeter. All State Plane Coordinates shall be in NAD 1983 State Plane Pennsylvania South. 1 Mylar, 2 copies and a compact disk (CD) of the Plan must be provided for those facilities where ownership and maintenance responsibility will be transferred to the Authority.

“As-Built” Plans Submission Requirements

ATTENTION! The Owner/Developer (and his Engineer and/or Contractor) is hereby Notified that Upper Yoder Township Authority has very specific G.P.S. based surveying and mapping requirements relative to acceptable “As-Built Plans.” These requirements must be met and the As-Built documentation provided in acceptable format BEFORE service will be provided to any prospective customer, and BEFORE Upper Yoder Township Authority will formally approve the completed Development.

1. Plans shall be prepared using a computer aided design (CAD) system of, or compatible with, AutoCAD Release 14 or later version. All Specifications and Addenda shall be provided in Microsoft Word format. Plans shall be in State Plane Coordinates (SPC), NAD 1983 Pennsylvania State Plane South. Plans shall include and show at least two (2) survey control points, showing their State Plane Coordinates. The Plans shall also include at least two (2) permanent Benchmarks, with their respective coordinates, and elevations tied to USGS Datum based on the As-Built elevation of Upper Yoder Township Authority’s closest such facility. The accuracy must be at least sub-centimeter Survey Grade. Plans shall be provided as; 1 Mylar, 2 Prints and 1 Compact Disk (CD) in a scale no smaller than 1” = 50’ HORIZONTAL and 1” = 10’ VERTICAL.
2. Field Survey (acquiring the As-Built GPS data) work shall be accomplished within Five (5) days following installation, and attested to via a “Note” on the Plan by the Surveyor.
3. Plans shall include a TITLE Sheet, showing the Project Name, Location, Owner’s Name/Address/Phone No. and the Engineer’s Name/Address/Phone Number. Each individual Sheet shall include the forgoing information and be individually Numbered, and include/note any subsequent Revisions and date of the As-Built Plan. Scale (Horizontal and/or Vertical) and North shall be indicated on each Sheet. The Seal of a Registered Engineer or Surveyor must be on each Sheet.
4. The perimeter corners shall be identified to correspond with a List/Chart showing the respective State Plane Coordinates of each.
5. A Sheet(s) showing Upper Yoder Township Authority’s “Standard Details” must be included.

6. Plans shall include ALL "non-Upper Yoder Township Authority" existing structures/features at the time of As-Built GPS data gathering. Such as Paving, Curbing, Signage, Catch Basins, etc.--- Other Utilities and their appurtenances. (Such Facilities shall be kept as a separate Layer on the provided As-Built CD).
7. Plans shall also include:
 - a. Existing and proposed contours in 2' intervals under a separate layer on the As-Built CD.
 - b. Name of existing streets, dedicated streets / alleys and their right of way widths.
 - c. Labeling of any and all private rights of ways for utilities.
 - d. Adjacent properties identifying address and owner.
 - e. Location of any and all proposed buildings / structures.
 - f. Reference of County Tax Map / Parcel No. that property is assigned.
 - g. Numbering / labeling of all lots to be serviced.

SANITARY SEWER:

- A. All manholes, lampholes, clean outs, viewports, wye fittings, etc. and the end of a service lateral must be identified (numbered or lettered) on the plan and listed in a chart specifying their respective State Plane Coordinates
- B. The size and material of the sanitary sewer mains / laterals and appurtenances must be indicated.
- C. Direction of flow, and Distance between manholes.
- D. A measurement from two (2) fixed points such as property corners to the end of the sewer lateral.
- E. The depth at the end of the sewer lateral.

SEWER PROFILES:

- A. Sanitary sewer elevations shall be based on USGS Datum.
- B. Each manhole, lamphole must be identified.
- C. Illustrate the size of pipe, its material and length along with its slope between the manholes.
- D. Provide Rim and Invert elevations of the manholes including the invert elevation for any "drop" connections.
- E. Illustrate the location of all wye fittings and which lot they are to service.
- F. Illustrate existing and finished grades (Existing – dotted line, Finished – solid line).

- G. Indicate the elevation and type of all facilities crossing the sanitary sewer main.

GENERAL: All coordinate data must be contained on a separate layer within the submitted CAD file

NOTICE! ---Upper Yoder Township Authority hereby reserves the right to waive, at its sole discretion, any and or all of the above requirements, dependent upon the scope (size or complexity) of the Development.

UYTA

Upper Yoder Township Authority

A PA Municipal Corporation

110 Sunray Drive, Suite 1
Johnstown, PA 15905
Phone: (814) 255-5243
Fax: (814) 255-1805

www.upperyodertownship.org

RATES AND FEES

Service Charges for Original Project, Benscreek Project, and Woodmont Project

Metered Service

All Customers Connected

Quarterly Charge

\$93.84 First 10,000 Gallons
\$12.51 Per Thousand after 10,000 Gallons

Services for Unmetered Customers

All unmetered customers charged same minimum rate as the metered customers of the same area.

Original Project	\$93.84 Quarterly Charge
Benscreek Project	\$93.84 Quarterly Charge
Woodmont Project	\$93.84 Quarterly Charge

Late Charges

Late charges are 5% on any balance due.

Non-Compliance Fees

FOR SINGLE FAMILY DWELLINGS:

1 – 12 months violation:	\$150 per quarterly billing
13 - 24 months violation:	\$225 per quarterly billing
25 months and beyond violation:	\$300 per quarterly billing

FOR CUSTOMERS OTHER THAN SINGLE FAMILY DWELLINGS:

(Multi-Family, Industrial and Commercial)

1 – 12 months violation:	\$150 per quarterly billing per EDU
13 - 24 months violation:	\$225 per quarterly billing per EDU
25 months and beyond violation:	\$300 per quarterly billing per EDU

Treatment Charges

(As imposed by the Johnstown Redevelopment Authority, or successor)

Unmetered Service

"Any customers not having metered water service will pay the quarterly minimum charge effective in their area until such time as meters are installed."

Connection Charges

Taps - Revised by formal motion during the June 20, 2005, Upper Yoder Township Authority regularly scheduled monthly meeting.

Connection Fee in all service areas will be based upon actual tap cost incurred by the Authority with a minimum Connection Fee and a maximum Connection Fee of the actual cost. A Tap Fee has been instituted for all service areas for the privilege of connecting to the Authority's sewer lines. The Tap Fee has been set at \$1,500.00. The inspection fee is \$75.00. Resolution No. 2-09-15-1

An inspection fee of \$75.00 will be charged on all taps that are made into private lines that eventually go into the Upper Yoder sewers. Inspection fees must be paid before building permits are issued. All work must be inspected by the Authority before same is covered over.

Fees

Returned Check Fee - \$50.00
Water Shut Off Fee - \$25.00
Certificate to Satisfy - \$3.00
Legal Fees as Applicable
Filing Fee - \$10.00
Satisfaction Fee or Lien Letter Request Fee - \$10.00

House Posting Fee - \$20.00
Water Restoration Fee - \$25.00
Attorney Fee as necessary

Cambria County Prothonotary fees for filing and Satisfaction as are established from time to time are subject to increase.